

**OPERATORS MANUAL  
FOR THE  
LH 85 – SPRAY CONTROLLER**

LH. No. 020-851-UK Version 1.00

**LH Technologies Denmark ApS**

Mølhavevej 2

9440 Aabybro

Denmark

Tlf. +45 9696 2500

Fax. +45 9696 2501

Internet: <http://www.lh-agro.com/>



# Introduction

INTRODUCTION .....	1.3
--------------------	-----

*We have endeavoured to deliver a fault free product. To ensure optimal use of the equipment we ask that great attention be paid when reading the manual. We are more than happy to help should any queries arise, both when the product is used for the first time and at any later date. Regarding responsibility for use of the product, we refer to our sales and delivery terms especially paragraph 7, which follows:*

7. Product usage.

7.1 Any use of the product is at the sole risk of the buyer. The buyer is therefore not entitled to any form for compensation caused by, for example, any of the following:

- Disturbance to/from any electronic services or products that do not confirm to the standards for CE marking,
- Missing or poor signal coverage or a succession hereof from external transmitters/receivers, used by the buyer,
- Functional faults, which apply to or from a PC-program or PC-equipment, not delivered by the seller,
- Faults that may arise from the buyers negligence to react to warnings and fault messages from the product, or which can be traced to negligence and/or absent constant control of the work carried out in comparison to the planned job.

7.2 When implementing any new equipment the buyer must take great care and pay attention. Any doubts as to correct operation/use should result in contacting the sellers service department.

This manual may not be altered, copied or manipulated in any way. Unoriginal manuals can lead to operational faults damaging machines or crops as a consequence thereof. LH Technologies Denmark ApS can therefore not be held responsible for damages incurred, which can be traced to the use of unoriginal or manipulated manuals. Original manuals can be requisitioned at any time from your dealer.

With regards

**LH Technologies Denmark ApS**

Mølhavevej 2

9440 Aabybro

Denmark

Tel. +45 96 96 25 00

Fax. +45 96 96 25 01

**Internet:** <http://www.lh-agro.com/>

---

## INTRODUCTION

---

The LH 85 Spray Controller is not only a powerful spray rate controller, but also a command centre for the whole sprayer!

Whilst designing this unit we have tried hard to ensure that operation is as simple as possible, the ergonomically designed housing and the menu based operating system ensure that the unit will be a pleasure to use for many years.

A large amount of the system is built up around easily understood icons and instructions on the display in clear text make this operator's manual almost redundant, however we recommend that this manual be used as a reference for the many functions available.

Despite the fact that this manual is large and may, upon first impressions, seem to be too much to read, we ask you to study at least chapter 2 where the basic functions of the system are explained.

Examples are used throughout this manual to ensure that finding a solution to any problems that might arise can be solved simply by changing the values in the examples with the values required for the task in hand.

Our experience tells us that it is a good idea to familiarise yourself with the system **before** the first day of use thus avoiding delays in getting the job done!

Please keep this operator's manual within easy reach and together with the LH 85.



# General operation

OPERATING THE LH 85 SPRAY CONTROLLER .....	2.2
THE SPRAY CONTROLLER SYSTEM OUTLINE .....	2.2
CONTROLLER SECTION (A) .....	2.3
SWITCH SECTION (B) .....	2.3
SWITCH SECTION OVERVIEW .....	2.4
POWER ON/OFF SWITCH (POS. B1).....	2.4
AGITATION SWITCH (POS.B2) .....	2.4
FILL FUNCTION SWITCH (POS. B3) .....	2.4
AUTOMATIC/MANUAL FUNCTION SWITCHES (POS. B4 & B5).....	2.4
MAIN ON/OFF SWITCH (POS. B6) .....	2.4
SWITCHES C1 TO C9 .....	2.4
SWITCHES D1 TO D9 .....	2.4
CONTROLLER OVERVIEW .....	2.5
DISPLAY (POS. A1).....	2.5
SETUP KEY (POS. A2).....	2.6
INFO KEY (POS. A3).....	2.6
JOB KEY (POS. A4).....	2.7
ESCAPE KEY (POS. A5) .....	2.7
ARROW KEYS (POS. A6, A8, A9, A10) .....	2.7
ENTER KEY (POS. A7) .....	2.7
CLEAR KEY (POS. 11) .....	2.7
FUNCTION KEY 1 (POS. A12) .....	2.7
FUNCTION KEYS 2 & 3 (POS. A13 & A14).....	2.8
FUNCTION KEY 4 (POS. A15) .....	2.8
NAVIGATING THROUGH THE MENUS.....	2.9
SELECTING AN ITEM FROM A MENU AND ALTERING A VALUE.....	2.9
SELECTING A VALUE FROM A LIST (CHECKBOXES) .....	2.12

# OPERATING THE LH 85 SPRAY CONTROLLER

The LH 85 spray controller system can be split into two sections:

The controller section (A)

The switch section (B, C & D)

## THE SPRAY CONTROLLER SYSTEM OUTLINE

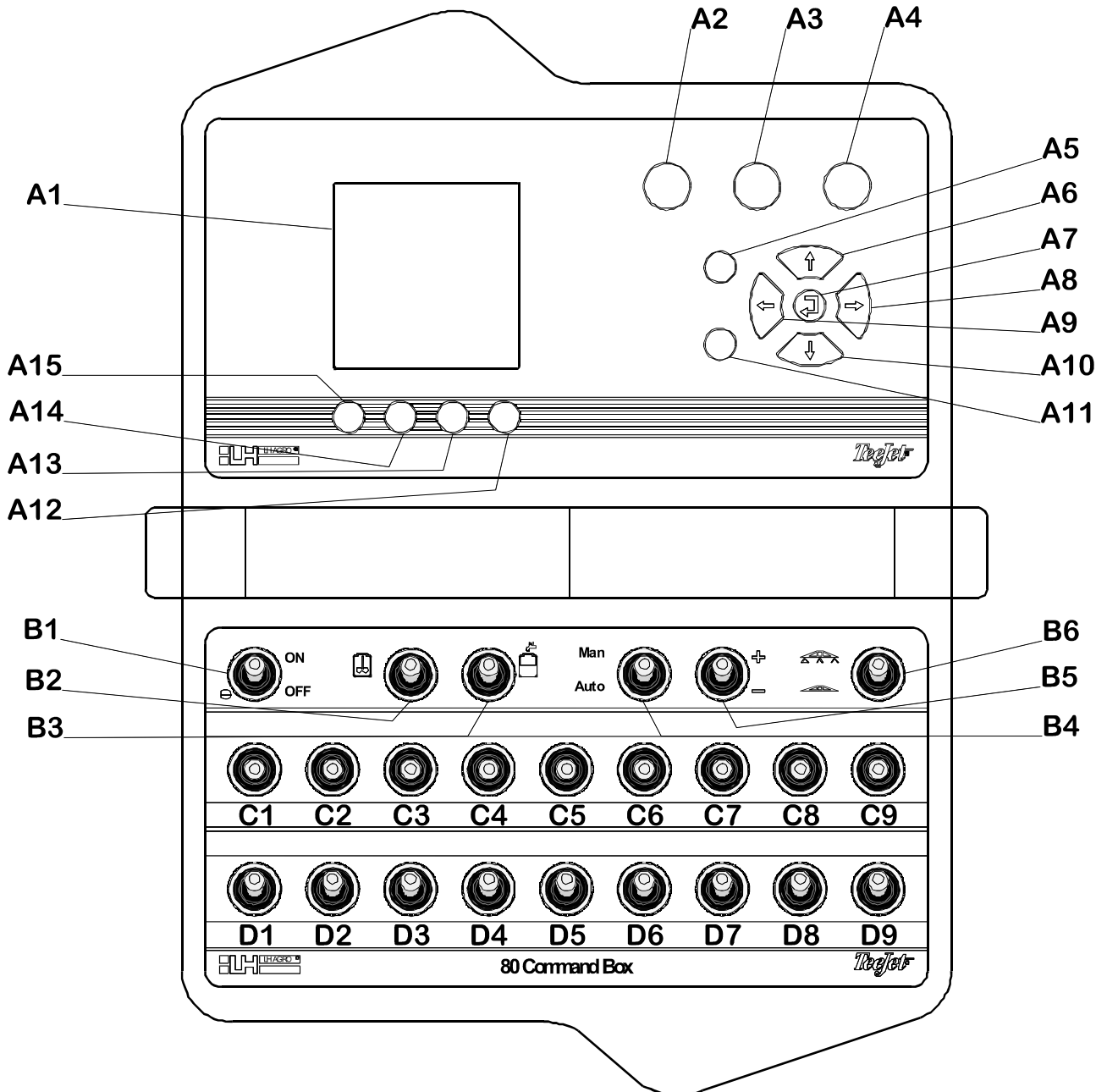

**CONTROLLER SECTION (A)**

Pos.	Description	Pos.	Description
A1	Display	A9	Left function key
A2	Setup key	A10	Down function key
A3	Info key	A11	Clear key
A4	Job key	A12	Function key 1
A5	Escape key	A13	Function key 2
A6	Up function key	A14	Function key 3
A7	Enter key	A15	Function key 4
A8	Right function key		

**SWITCH SECTION (B)**

Pos.	Description	Pos.	Description
B1	Power on/off switch	B4	Auto/man function switch
B2	Agitation switch	B5	Rate increase/decrease
B3	Fill function switch	B6	Main on/off

Pos.	Description
C1 – C9	Switch row C (functions depend on model)
D1 – D9	Switch row D (functions depend on model)

## SWITCH SECTION OVERVIEW

### POWER ON/OFF SWITCH (POS. B1)

This switch is used to switch the system on and off.

### AGITATION SWITCH (POS.B2)

This switch is used to switch the tank agitation on and off (if tank agitation is fitted).

### FILL FUNCTION SWITCH (POS. B3)

At present this switch has no function.

### AUTOMATIC/MANUAL FUNCTION SWITCHES (POS. B4 & B5)

The AUTO/MAN switch is used to change between automatic and manual spray rate control.

When this switch is in the "MAN" position (up) the spray rate can be controlled thus:

- The spray rate is **increased** by holding the RATE INCREASE/DECREASE switch **up**.
- The spray rate is **decreased** by holding the RATE INCREASE/DECREASE switch **down**.

When this switch is in the "AUTO" position (down) the spray rate is controlled automatically by the computer.

### MAIN ON/OFF SWITCH (POS. B6)

The main on/off switch is used to switch the main boom on & off.

- When the switch is in the up position the sprayer is on.
- When the switch is in the down position the sprayer is off.

The individual boom sections are typically switched on and off with the switches D1 to D9 depending on the LH 85 spray controller model.

### SWITCHES C1 TO C9

The function for the switches in this row depends on the sprayer.

### SWITCHES D1 TO D9

The function for the switches in this row depends on the sprayer.

# CONTROLLER OVERVIEW

## DISPLAY (POS. A1)

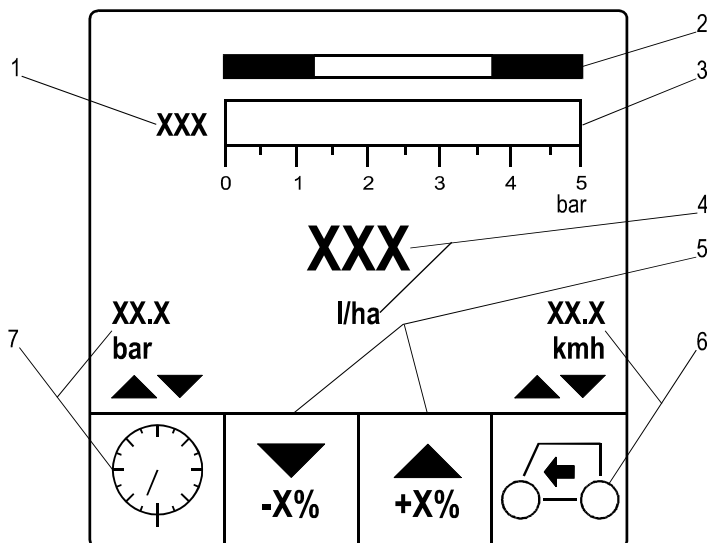

Pos.	Description	Pos.	Description
1	Selected nozzle type	5	Boost or manual +/-
2	Optimum pressure range	6	User selectable work information
3	Working pressure indicator	7	User selectable spray information
4	Application rate		

### Selected nozzle type (pos. 1):

The nozzle type selected is displayed here.

### Optimum pressure range (pos. 2):

The optimum working pressure range for the selected nozzle type is shown here.

### Working pressure indicator (pos. 3):

The current working pressure is shown. The range of the pressure indicator changes to suit, e.g. the selected nozzle type, working speed range, etc.

### Application rate (pos. 4):

The actual application rate shown in litres per hectare. The target rate is shown when the main on/off switch (B6) is in the off position.

**Boost or manual +/- (pos. 5):**

The function of these keys may change depending on whether automatic or manual rate control is selected in the "Fast setup" menu. See page 3.4

Increase or decrease the required application rate in steps using the function keys (A13 & A14). See page 2.8.

The size of the steps (percent of current rate) is encoded under MACHINE SETUP under "Boost" (see page 4.11).

When manual rate control has been selected from the "Fast setup" menu the function of the keys changes to manual rate increase (+) and manual rate decrease (-).

**User selectable work information (pos. 6):**

It is possible to select which work related information is displayed by pressing function key 1 (A12).

A description of the work related information that can be displayed can be seen on page 3.2.

**User selectable spray information (pos. 7):**

It is possible to select which spray related information is displayed by pressing function key 4 (A15).

A description of the spray related information that can be displayed can be seen on page 3.2.

**SETUP KEY (POS. A2)**

Key	Description
	The SETUP key is used to enter the setup menus. If the main on/off switch (B6) is in the on position the "Fast setup" menu is displayed (see page 3.4). If the main on/off switch (B6) is in the off position the main setup menu is shown. A description of the available settings can be seen in the "Encode" chapter of this operators manual.

**INFO KEY (POS. A3)**

Key	Description						
	Pressing the INFO key displays the following information (use the up & down arrow keys (A6 & A10) to highlight and the ENTER key (A7) to select. A detailed description of each function can be seen on page 3.3:  <table style="width: 100%; border: none;"> <tr> <td style="width: 33%;">• Controller</td> <td style="width: 33%;">• Counters</td> <td style="width: 33%;">• Export/Import</td> </tr> <tr> <td>• Diagnostics</td> <td>• Alarm log</td> <td>• Active alarms</td> </tr> </table>	• Controller	• Counters	• Export/Import	• Diagnostics	• Alarm log	• Active alarms
• Controller	• Counters	• Export/Import					
• Diagnostics	• Alarm log	• Active alarms					

**JOB KEY (POS. A4)**

Key	Description
	The JOB key is used for the task function. A description of the task function can be seen on page 5.1.

**ESCAPE KEY (POS. A5)**

Key	Description
	The ESCAPE key is used to return to the previous menu <b>without</b> saving any alterations.

**ARROW KEYS (POS. A6, A8, A9, A10)**

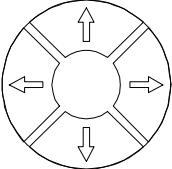
Key	Description
	The arrow keys are used to select and alter an encodement. When encoding a value the arrow keys are used to select and adjust the digit that needs changing. Each digit can be set from 0 to 9 with the ARROW UP/DOWN keys. The ARROW RIGHT/LEFT keys are used to select the digit to be altered.

**ENTER KEY (POS. A7)**

Key	Description
	The enter key is used to <b>accept</b> settings and to <b>return</b> to the previous screen.

**CLEAR KEY (POS. 11)**

Key	Description
	The clear key is used to <b>reset</b> settings/counters and to <b>accept</b> warnings.

**FUNCTION KEY 1 (POS. A12)**

Key	Description
	Pressing this key during operation pages through and selects the user selectable work related information to be shown on the display. A description of the work related information that can be displayed can be seen on page 3.2.

**FUNCTION KEYS 2 & 3 (POS. A13 & A14)**

Key	Description
 Keys 2 & 3	<p>The function of these keys may change depending on whether automatic or manual rate control is selected in the "Fast setup" menu. See page 3.4</p> <p>Increase or decrease the required application rate in steps using these function keys.</p> <p>When manual rate control has been selected from the "Fast setup" menu the function of the keys changes to manual rate increase (+) and manual rate decrease (-).</p>

**FUNCTION KEY 4 (POS. A15)**

Key	Description
 Key 4	<p>Pressing this key during operation pages through and selects the user selectable spray related information to be shown on the display.</p> <p>A description of the spray related information that can be displayed can be seen on page 3.2.</p>

## NAVIGATING THROUGH THE MENUS



The LH 85 Spray controller uses a menu based structure for most functions. Navigation through the menus is simple and unified throughout the whole programme.



### SELECTING AN ITEM FROM A MENU AND ALTERING A VALUE

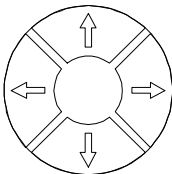

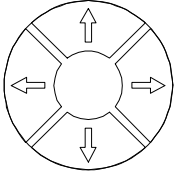

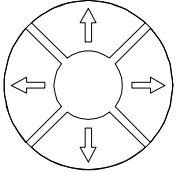
The procedure to select and alter a setting in the LH 85 Spray controller is simple and requires very little practice.

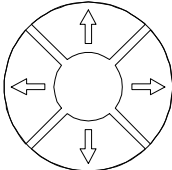
The procedure to navigate, select and alter a setting is best illustrated with an **example**, which follows:

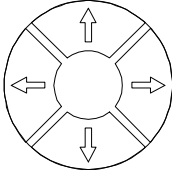
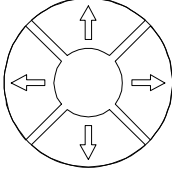
Step	Key	Action
<b>To alter the nozzle configuration for a programmable nozzle (P1).</b>		
1		Switch the main on/off switch (pos. B6) to the OFF position (down).
2		Press the SETUP key and the following is shown in the display: <div style="border: 1px solid black; padding: 10px; margin: 10px 0;"> <div style="text-align: right; border: 1px solid black; display: inline-block; padding: 2px 5px;">Setup</div>   <b>User</b>  <b>Machine</b>  <b>OEM</b>  <b>Console</b> </div>
3		Press the ARROW DOWN key to move the cursor to "Machine" <div style="border: 1px solid black; padding: 10px; margin: 10px 0;"> <div style="text-align: right; border: 1px solid black; display: inline-block; padding: 2px 5px;">Setup</div>   <b>User</b>  <b>Machine</b>  <b>OEM</b>  <b>Console</b> </div>

Step	Key	Action										
4		<p>Press the ENTER key to select "Machine" and the first 5 available settings are shown in the display.</p> <div data-bbox="600 331 1003 734" style="border: 1px solid black; padding: 5px;"> <p style="text-align: center;">Machine</p> <p><b>Go to manual</b></p> <p>Speed source</p> <p>Flow</p> <p>Boost</p> <p>Regulation action</p> <p style="text-align: center;">↓       ↓       ↓</p> </div> <p><i>Notice the 3 arrows pointing down at the bottom of the display.</i></p> <p><i>This indicates that further menu items are available on another page.</i></p>										
5		<p>Press the ARROW DOWN key 6 times to highlight "Nozzle configuration".</p> <div data-bbox="600 831 1003 1234" style="border: 1px solid black; padding: 5px;"> <p style="text-align: center;">Machine</p> <p style="text-align: center;">↑       ↑       ↑</p> <p>Flow</p> <p>Boost</p> <p>Regulation action</p> <p>Nozzle body</p> <p><b>Nozzle configuration</b></p> </div> <p><i>Notice the 3 arrows pointing up at the top of the display.</i></p> <p><i>This indicates that further menu items are available on another page.</i></p>										
6		<p>Press the ENTER key to select "Nozzle configuration" and the available settings are shown:</p> <div data-bbox="600 1330 1003 1733" style="border: 1px solid black; padding: 5px;"> <p style="text-align: center;">Nozzle type</p> <p style="text-align: center;">Active: 03</p> <table border="0" style="width: 100%; border-collapse: collapse;"> <tr> <td style="border-bottom: 1px solid black;"><b>01 (Orange)</b></td> <td style="border-bottom: 1px solid black; text-align: right;"><b>0.32</b></td> </tr> <tr> <td>015 (Green)</td> <td style="text-align: right;">0.48</td> </tr> <tr> <td>02 (Yellow)</td> <td style="text-align: right;">0.64</td> </tr> <tr> <td>025 (Olive green)</td> <td style="text-align: right;">0.81</td> </tr> <tr> <td>03 (Blue)</td> <td style="text-align: right;">0.97</td> </tr> </table> <p style="text-align: center;">↓       ↓       ↓</p> </div>	<b>01 (Orange)</b>	<b>0.32</b>	015 (Green)	0.48	02 (Yellow)	0.64	025 (Olive green)	0.81	03 (Blue)	0.97
<b>01 (Orange)</b>	<b>0.32</b>											
015 (Green)	0.48											
02 (Yellow)	0.64											
025 (Olive green)	0.81											
03 (Blue)	0.97											
7		<p>Repeatedly press the ARROW DOWN key until "P1" is highlighted.</p>										





Step	Key	Action								
8		<p>Press the ENTER key to select the configuration menu for the selected nozzle.</p> <div style="border: 1px solid black; padding: 10px; margin: 10px 0;"> <p style="text-align: center;">Nozzle : P 1</p> <table style="width: 100%; border-collapse: collapse;"> <tr> <td style="border-bottom: 2px solid black; padding: 2px;">Low limit</td> <td style="padding: 2px;">0.00</td> </tr> <tr> <td>High limit</td> <td>0.00</td> </tr> <tr> <td>Ref. flow</td> <td>0.00</td> </tr> <tr> <td>Ref. pressure</td> <td>0.00</td> </tr> </table> </div>	Low limit	0.00	High limit	0.00	Ref. flow	0.00	Ref. pressure	0.00
Low limit	0.00									
High limit	0.00									
Ref. flow	0.00									
Ref. pressure	0.00									
9		<p>Highlight the setting to be altered using the ARROW UP and DOWN keys.</p>								
10		<p>Press the ENTER key when the setting to be altered is highlighted.</p>								
11		<p>Highlight the digit to be altered by using the ARROW LEFT and RIGHT keys.</p> <div style="border: 1px solid black; padding: 10px; margin: 10px 0;"> <p style="text-align: center;">P 1: Low limit</p> <p style="text-align: center; font-size: 24px;"><b>0</b> . 00 bar</p> </div>								
12		<p>Using the ARROW UP and DOWN keys change the digit to the required value. To reset a value simply press the <b>C</b> key.</p> <div style="border: 1px solid black; padding: 10px; margin: 10px 0;"> <p style="text-align: center;">P 1: Low limit</p> <p style="text-align: center; font-size: 24px;"><b>1</b> . 00 bar</p> </div>								

Step	Key	Action
13		Press the ENTER key to store the value and return to the previous screen.
14	 or  or 	Repeat steps 9 to 13 until all of the required changes have been made. Then press the ESCAPE key to return to the previous menu <b>or</b> press the SETUP key to return to the main menu <b>or</b> press the JOB key to return directly to the main operating screen.

### SELECTING A VALUE FROM A LIST (CHECKBOXES)

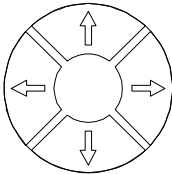
Some settings have a list of options to select from. The procedure for selecting the required setting is similar to the above; a checkbox is used instead of a numerical value.

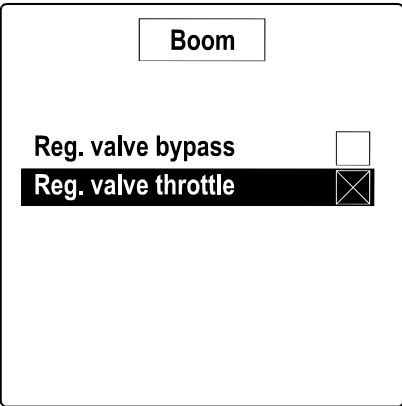
An **example** follows:

Step	Key	Action
1		Highlight the setting to be selected using the ARROW UP and DOWN keys.
2		Press the ENTER key to select the option. 
3		Then press the ESCAPE key to return to the previous menu <b>or</b> press the SETUP key to return to the main menu <b>or</b> press the JOB key to return directly to the main operating screen.





# Operation

OPERATION.....	3.2
USER SELECTABLE SPRAY RELATED INFORMATION.....	3.2
USER SELECTABLE WORK RELATED INFORMATION.....	3.2
INFO MENU .....	3.3
FAST SETUP MENU.....	3.4
GO TO MANUAL.....	3.5
SPEED SOURCE.....	3.5
REGULATION BASE .....	3.6
BACKLIGHT.....	3.6





## OPERATION





**All settings should be encoded/checked before any spray work commences. Please refer to the SETTINGS section of this manual for a description of the available settings.**

### USER SELECTABLE SPRAY RELATED INFORMATION

Symbol	Description
	<b>Working pressure:</b> The current working pressure shown as bar.
	<b>Flow rate:</b> The present flow rate shown in litres per hour.
	<b>Sprayed volume:</b> The amount sprayed since the task was started or since the counter was reset.
	<b>Volume left:</b> The amount remaining for the present field or task.
	<b>Density:</b> The density of the liquid being used.

### USER SELECTABLE WORK RELATED INFORMATION

Symbol	Description
	<b>Forward speed:</b> The present forward speed shown as kilometres per hour.
	<b>Working width:</b> The present working width shown as metres.
	<b>Area covered:</b> The total area covered shown as hectares with 2 decimals since the task was started or since the counter was reset. <i>Area is only measured when the sprayer is in work.</i>
	<b>Area left:</b> The area that can be covered with the current tank content. <i>This calculated figure is based on the present volume in the tank, the actual application rate and the current working width.</i>
	<b>Work efficiency:</b> The present work efficiency shown as hectares per hour. <i>This calculated value is based on the actual forward speed and the present working width.</i>

Symbol	Description
	<b>Distance covered:</b> The distance covered shown as metres since the task was started or since the counter was reset. <i>Distance is only measured when the sprayer is in work.</i>
	<b>Distance left:</b> The distance that can be covered with the current tank content. <i>This calculated figure is based on the present volume in the tank, the actual application rate and the current working width</i>
	<b>Elapsed time:</b> The time passed since the task was started or since the counter was reset. <i>Time is only measured when the sprayer is in work.</i>
	<b>Wind speed:</b> The current wind speed shown in metres per second. <i>This function is only possible when the main on/off switch is in the off position and the forward speed = 0 and if the system is fitted with an anemometer.</i>

### INFO MENU

Pressing the INFO key displays the following menu structure.

Each item in the menu is described in the following:

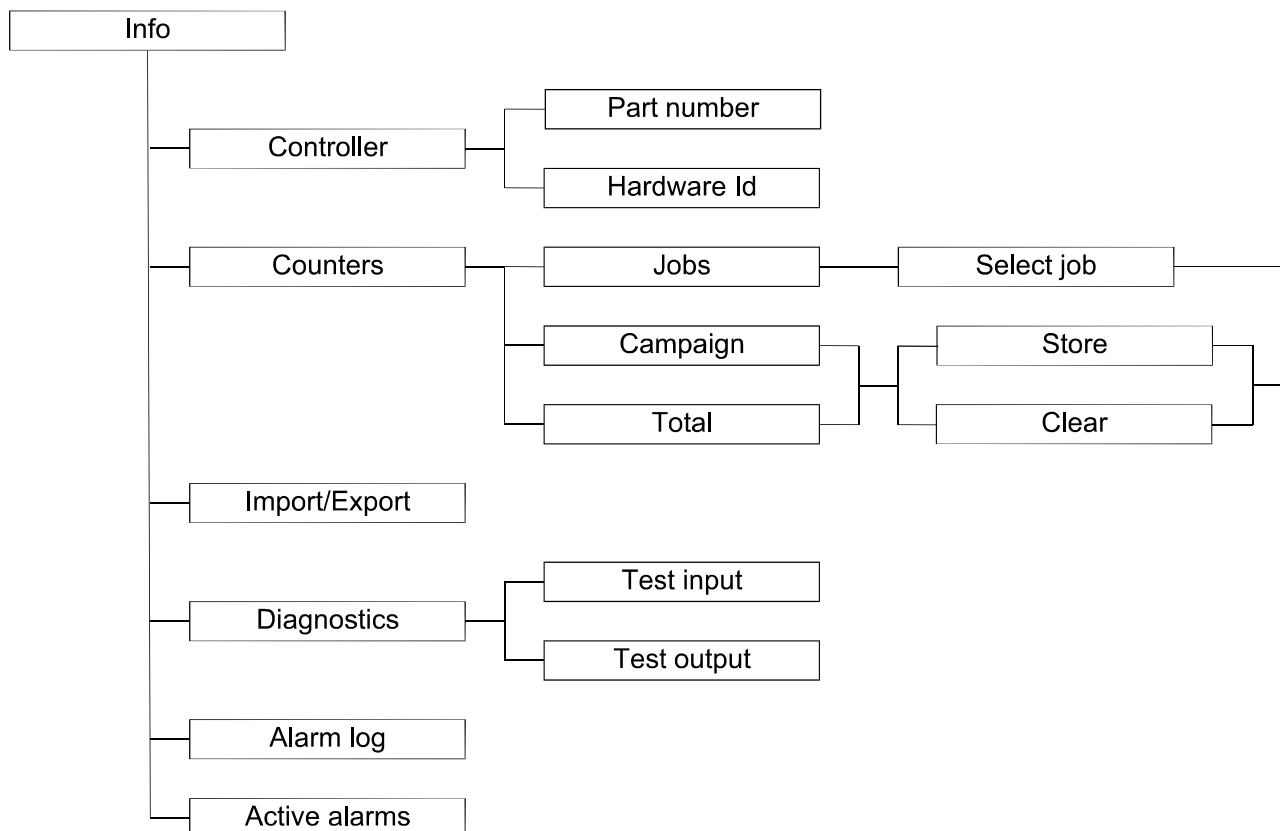

**Controller:**

Selecting controller displays the hardware Id and part number of the LH 85 Spray controller.

**Counters:**

There are three counter sets available in the LH 85 Spray controller. A brief description can be seen in the following, for a more detailed description please see the "Job Function" section of this manual (page 5.1):

- Jobs:** Each of the 16 jobs can be viewed, stored or cleared individually.
- Campaign:** A total counter for, e.g. the season. The campaign counters can be viewed, stored or cleared. A password is required to clear the campaign counter.
- Total:** Data is constantly added to the total counter. The total counter can be viewed, stored or cleared. A password is required to reset the total counter.

**Import/Export:**

This menu item currently has no function.

**Diagnostics:**

Should problems arise with the system the inputs and outputs of the LH 85 Spray controller can be tested using this menu item.

Please refer to the "System" section of this manual (page 6.1) for a description of the various inputs and outputs.

**Alarm log:**

This menu item currently has no function.

**Active alarms:**

This menu item currently has no function.

**FAST SETUP MENU**

When the system is in work (spraying) pressing the SETUP key selects the "Fast Setup" menu.

The settings in this menu are directly related to spray work and allow the available settings to be altered whilst spraying.

Each item in the menu is described in the following:

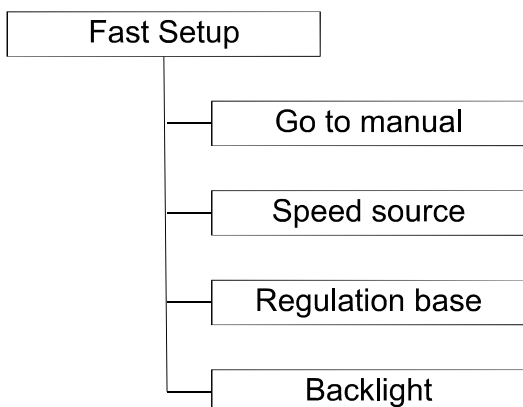

### GO TO MANUAL

Using this function it is possible to change from automatic rate control to manual rate control and back to automatic rate control again.

The function of the boost keys (pos. A13 & A14) changes to manual increase/decrease when manual rate control is selected and the rate can be altered using these keys.









- Pressing the + key increases the rate.
- Pressing the – key decreases the rate.

To return to automatic rate control again simply press the SETUP key and select "Go to automatic"

### SPEED SOURCE

It is possible to change the sensor, from which the forward speed signal is received and used for regulation, during operation by using this function.

This function can be used when, e.g. different wheels are used on the implement. A description of the available forward speed inputs can be seen in the following:

Symbol	Description
	<b>Radar</b> Pressing this key selects a signal from a radar sensor.
	<b>Tractor wheel</b> Pressing this key selects a signal from a sensor fitted to the tractor.
	<b>Implement wheel 1</b> Pressing this key selects a signal from a sensor fitted to the implement.
	<b>Pressing this key will show the next page and display the following</b>
	<b>Implement wheel 2</b> Pressing this key selects a signal from a sensor fitted to the implement.
	<b>Implement wheel 3</b> Pressing this key selects a signal from a sensor fitted to the implement
	<b>Simulated speed</b> Pressing this key selects simulated forward speed. When simulated speed has been selected function keys 2 & 3 (pos. A13 & A14) will allow the speed to be increased or decreased. <i>The speed to be simulated is encoded in the "Machine setup" menu under "Speed source" (page 4.8).</i>
	<b>Pressing this key will show the first page</b>



**For correct operation the speed signal sources to be used must be calibrated accurately. The procedure for forward speed calibration can be seen on page 4.5.**

## REGULATION BASE

*This menu item might not appear depending on model/settings.*

If the system is fitted with a pressure sensor **and** a flowmeter it is possible to select which sensor should be used for measuring flow (and thus for rate control).

The following options are available:

Symbol	Description	
	<b>Flowmeter</b>	Pressing this key selects flow based regulation.
	<b>Pressure sensor</b>	Pressing this key selects pressure based regulation.
AUTO	<b>Auto</b>	When this key is pressed the LH 85 Spray controller selects which flow input to be used based on the minimum flow setting for the flowmeter.

## BACKLIGHT

The contrast and backlight settings for the display can be adjusted during operation. Please refer to "Contrast/Light" on page 4.24 in the SETTINGS section of this manual for detailed information.

# Settings

USER SETUP .....	4.3
JOB .....	4.4
TANK FILLING .....	4.4
TANK LEVEL .....	4.4
TRANSMIT .....	4.4
MACHINE SETUP .....	4.4
GO TO MANUAL .....	4.5
SPEED SOURCE .....	4.5
SPEED SENSOR SELECTION AND CALIBRATION .....	4.6
SIMULATED SPEED .....	4.8
FLOW .....	4.9
AUTOMATIC FLOWMETER CORRECTION .....	4.10
MANUAL FLOWMETER CORRECTION .....	4.11
BOOST .....	4.11
REGULATION ACTION .....	4.11
FAST REGULATION VALUE .....	4.11
PRECISE REGULATION VALUE .....	4.12
NOZZLE BODY .....	4.12
NOZZLE CONFIGURATION .....	4.13
OEM SETUP .....	4.15
UNIT .....	4.16
SENSORS .....	4.16
PRESENCE .....	4.16
CALIBRATION .....	4.16
BOOM .....	4.19
BOOM SECTIONS .....	4.19
NOZZLES PER SECTION .....	4.19
NOZZLE SPACING .....	4.20
REGULATION VALVES .....	4.20
SECTION VALVES .....	4.20
REGULATION DETAILS .....	4.20
TANK .....	4.22
MAXIMUM TANK CONTENT .....	4.22
AUTO FILLING .....	4.22
ELECTRIC AGITATION .....	4.22
MINIMUM TANK VOLUME .....	4.22
AUTO FILLING OFFSET .....	4.22
ALARM CONFIGURATION .....	4.22
MINIMUM TANK CONTENT ALARM .....	4.22
FLOW/PRESSURE CROSS-CHECK .....	4.23
COMMUNICATION .....	4.23
MOTOR MANAGEMENT .....	4.23

---

CONSOLE SETUP ..... 4.23

    CONTRAST/LIGHT ..... 4.24

    LANGUAGE ..... 4.24



    DATE/TIME ..... 4.24

    BUZZER ..... 4.25

    FILE SYSTEM ..... 4.25

## USER SETUP

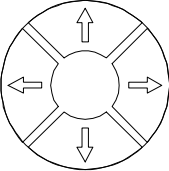
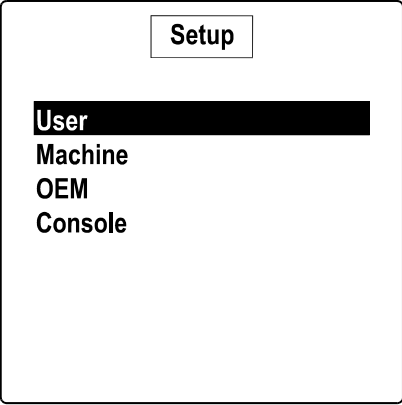
The settings in the USER setup menu are related to daily work. The procedure to access the "User setup" menu is thus:

Step	Key	Action
1		Switch the main on/off switch (B6) to the off position.
2		Press the SETUP key.
3		Highlight the "User" menu item using the ARROW UP and DOWN keys. 
4		Press the ENTER key to select.

The following diagram shows the menu structure of the "User" setup menu:

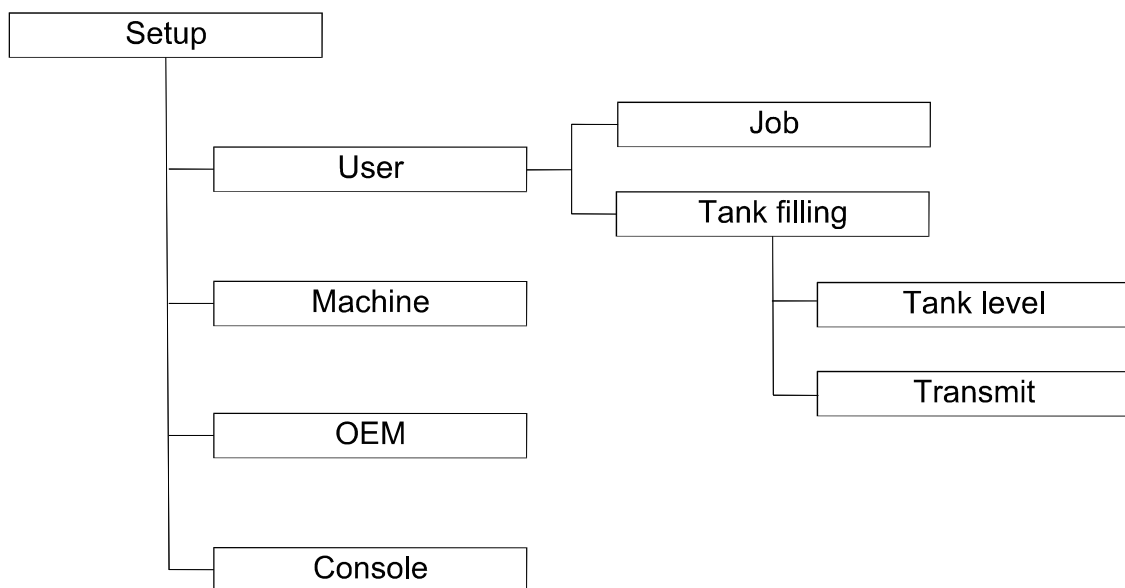

A description of each setting is described in the following:

## JOB

For a detailed description of the "Job" menu item please see the JOB FUNCTION section of this manual.

## TANK FILLING

### TANK LEVEL

Encode the actual tank content in litres.

This value is used for the following calculated information:



- Volume left.
- Area left.
- Distance left.

### TRANSMIT

This menu item currently has no function.

## MACHINE SETUP

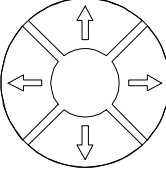
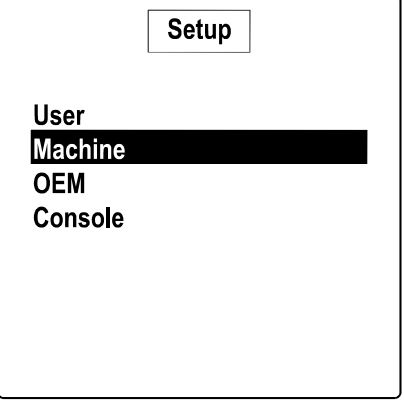
The "Machine" settings relate directly to settings that can differ from machine to machine. The procedure to access the "Machine setup" menu is similar to the procedure for accessing the "User setup" menu however the procedure is described below:

Step	Key	Action
1		Switch the main on/off switch (B6) to the <b>OFF</b> position.
2		Press the SETUP key.
3		Highlight the "Machine" menu item using the ARROW UP and DOWN keys. 
4		Press the ENTER key to select.

Once selected, the following menu structure is available, a detailed description of each setting can be seen after the diagram:

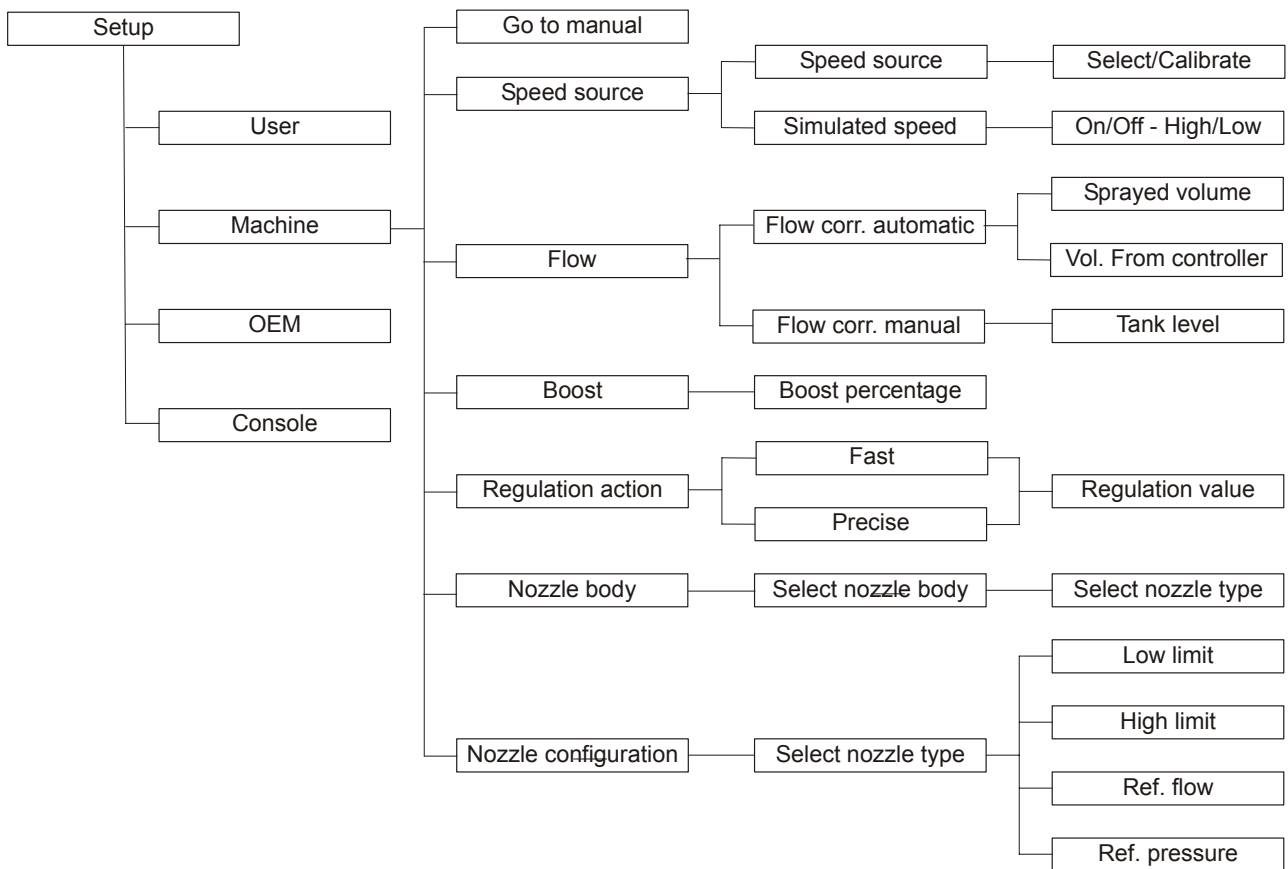

## GO TO MANUAL

This function is described under the "Fast setup" section on page 3.4.

## SPEED SOURCE

The sensor to be used for forward speed and thus regulation can be selected and calibrated here. It is also possible to simulate forward speed with the LH 85 Spray controller, which is useful for, e.g. flowmeter calibration.

### SPEED SENSOR SELECTION AND CALIBRATION

Upon selecting this menu the following is displayed:

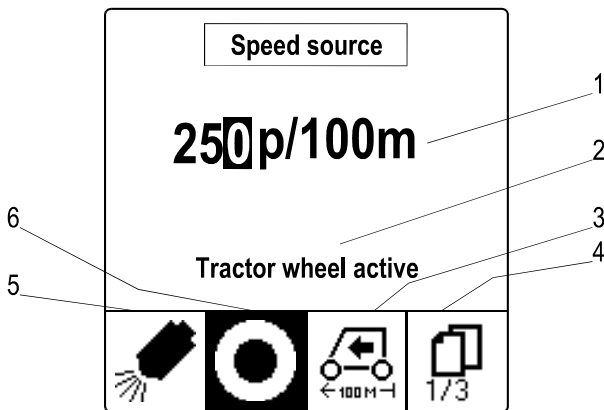





Pos.	Description	Pos.	Description
1	Current calibration figure	4	Page key
2	Currently selected sensor	5	Function key 4 (select sensor)
3	Calibrate key	6	Function key 3 (select sensor)

The forward speed sensors available can be seen in the following:

Symbol	Description
	<b>Radar</b> Pressing this key selects a signal from a radar sensor.
	<b>Tractor wheel</b> Pressing this key selects a signal from a sensor fitted to the tractor.
	<b>Pressing this key will show the next page and display the following</b>
	<b>Implement wheel 1</b> Pressing this key selects a signal from a sensor fitted to the implement.
	<b>Implement wheel 2</b> Pressing this key selects a signal from a sensor fitted to the implement.
	<b>Pressing this key will show the next page and display the following</b>
	<b>Implement wheel 3</b> Pressing this key selects a signal from a sensor fitted to the implement
	<b>Pressing this key will show the first page</b>



**Automatic speed sensor calibration:**

The procedure to calibrate the forward speed sensor follows:

Step	Key	Action
1		Measure and mark a 100 metre stretch in the field. Drive to the start mark and stop. <i>When calibrating the forward speed sensor we recommend doing so in the field with ½ the total volume in the tank to ensure conditions as close to spray work as possible.</i>
2		From the "Machine" setup menu select " <b>Speed source</b> ".
3		From the "Speed source" menu select " <b>Speed source</b> " this screen is shown in the display. <div style="border: 1px solid black; padding: 10px; margin: 10px 0; text-align: center;"> <p>Speed source</p> <p><b>250p/100m</b></p> <p>Tractor wheel active</p>  </div>
4	 Keys 3 & 4	Select the speed sensor to be calibrated by using function keys 3 & 4 (pos. 5 & 6 in the above). Use the page key (pos. 4 in the above) to view/select other sensors.
5		Press the CALIBRATE key once.
6		Drive the 100 metre stretch – the controller will count the number of pulses received whilst driving.
7		Stop <b>exactly</b> at the stop mark of the 100 metre stretch.
8		Press the ENTER key and the forward speed sensor has been calibrated.



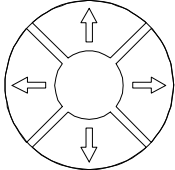



**Manual speed sensor calibration:**

If the number of pulses received per driven 100 metres is known then this can be encoded directly thus:

Step	Key	Action
1		From the "Machine" setup menu select " <b>Speed source</b> ".
2		From the "Speed source" menu select " <b>Speed source</b> ".
3	 Keys 3 & 4	Select the speed sensor to be calibrated by using function keys 3 & 4 (pos. 5 & 6 in the above). Use the page key (pos. 4 in the above) to view/select other sensors.
4		Encode the number of pulses per 100 metres using the ARROW keys.
5		Press the ENTER key and the forward speed sensor has been calibrated.

**SIMULATED SPEED**







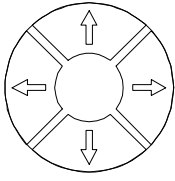

To use simulated forward speed in the LH 85 Spray controller do as follows:

Step	Key	Action				
1		From the "Machine" setup menu select " <b>Speed source</b> ".				
2		From the "Speed source" menu select " <b>Simulated speed</b> ".  <div style="border: 1px solid black; padding: 5px; width: fit-content; margin: 0 auto;"> <p style="text-align: center; border: 1px solid black; display: inline-block;">Simulated speed</p></div> <table style="margin: 0 auto;"> <tr> <td>Sim. low</td> <td style="text-align: right;">6.0 kmh</td> </tr> <tr> <td>Sim. high</td> <td style="text-align: right;">9.0 kmh</td> </tr> </table> <p style="text-align: center;">Simulate = Off</p> <div style="display: flex; justify-content: space-around; align-items: center;">     </div>	Sim. low	6.0 kmh	Sim. high	9.0 kmh
Sim. low	6.0 kmh					
Sim. high	9.0 kmh					
3		Press the "Low" speed key and enter the lowest speed to be simulated in kilometres per hour with 1 decimal.				
4		Press the ENTER key.				
5		Press the "High" speed key and encode the highest speed to be simulated in kilometres per hour with 1 decimal.				

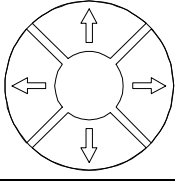

### AUTOMATIC FLOWMETER CORRECTION

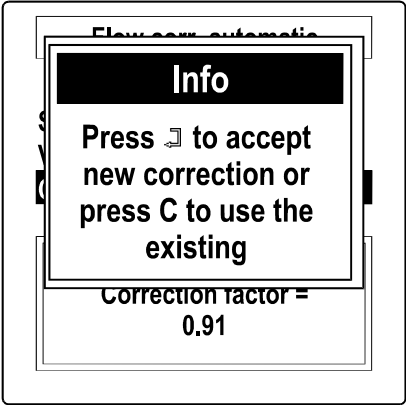
The procedure for automatically adjusting the flow meter calibration is as follows:



Step	Key	Action
1		Reset the litre counter as described in the JOB FUNCTION section in this manual.
2		Spray a known amount from the tank, e.g.500 litres.
3		Make a note of the amount the controller shows as sprayed.
4		From the "Machine" setup menu select " <b>Flow</b> ".
5		From the "Flow" menu select " <b>Flow corr. automatic</b> ". <i>The current flow meter correction value is shown at the bottom of the screen.</i>
6		Select " <b>Sprayed volume</b> " from the menu and encode the actual amount sprayed, e.g. 500 litres using the ARROW keys.
7		Press the ENTER key.
8		Select " <b>Vol. from controller</b> " from the menu and encode the volume noted in step 3 using the ARROW keys.
9		Press the ENTER key.
10		Highlight " <b>Calc. new flow corr.</b> " from the menu and press the ENTER key – the new flow meter correction value is displayed at the bottom of the screen.
11		Press the ESCAPE key and a prompt will appear asking to accept the new factor or to continue using the existing factor. 
12		Press the ENTER key to accept the new factor. <i>To continue using the old factor press the CLEAR key.</i>

### MANUAL FLOWMETER CORRECTION

The flowmeter correction factor can be encoded manually. To calculate the flowmeter correction factor the following formula can be used.

$$\text{Flow correction factor} = \frac{\text{Sprayed volume}}{\text{Volume from controller}}$$

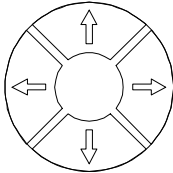
The procedure to encode the calculated flow correction factor is as follows:

Step	Key	Action
1		From the "Machine" setup menu select " <b>Flow</b> ".
2		From the "Flow" menu select " <b>Flow corr. manual</b> ".
3		Encode the new flow correction factor using the ARROW keys. Use this formula to calculate the new flow factor
4		Press the ENTER key and the new value is stored.

### BOOST

The size of the steps which the rate will increase or decrease with when the boost function is used.

The percentile value encoded is used for both "Boost increase" (+) and "Boost decrease" (-).

- Minimum value = 1%
- Maximum value 20%

### REGULATION ACTION

The regulation action values are used to adjust the "speed" at which the system adjusts the regulation valve.

The fast regulation action value brings the actual rate quickly towards the required rate. As the actual rate gets closer to the required rate the precise regulation action value takes over and controls the valve in smaller "steps".

The two different values used (fast & precise) are explained in the following:

#### FAST REGULATION VALUE

The fast regulation action value affects regulation when the actual rate is far from the required rate.

If the system is too slow to find the correct rate then the values should be increased.

If the system is too unstable then the values should be decreased.

### PRECISE REGULATION VALUE

The precise regulation action value affects regulation when the actual rate is close to the required rate

If the system is too slow to find the correct rate then the values should be increased.

If the system is too unstable then the values should be decreased.



### NOZZLE BODY

This menu allows the nozzle body to be configured with up to five different commonly used nozzle types, which can then be selected easily for the sprayer task (JOB FUNCTION).

Each nozzle type can be configured under "Nozzle configuration" (page 4.13).

The procedure to configure the nozzle body is as follows:

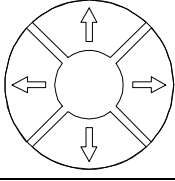
Step	Key	Action										
1		From the "Machine" setup menu select " <b>Nozzle body</b> " and this is shown in the display. <div data-bbox="598 916 1002 1319" style="border: 1px solid black; padding: 5px; margin: 10px 0;"> <div style="text-align: center; border: 1px solid black; width: fit-content; margin: 0 auto; padding: 2px;">Nozzle body</div> <table style="width: 100%; border-collapse: collapse;"> <tr><td style="width: 20px;">1</td><td>01 (Orange)</td></tr> <tr><td>2</td><td>015 (Green)</td></tr> <tr><td>3</td><td>02 (Yellow)</td></tr> <tr><td>4</td><td>04 (Blue)</td></tr> <tr><td>5</td><td>04 (Red)</td></tr> </table> </div>	1	01 (Orange)	2	015 (Green)	3	02 (Yellow)	4	04 (Blue)	5	04 (Red)
1	01 (Orange)											
2	015 (Green)											
3	02 (Yellow)											
4	04 (Blue)											
5	04 (Red)											
2		Highlight one of the nozzle types (1 to 5) using the ARROW KEYS										
3		Press the ENTER key to select the nozzle body spray outlet and the following is shown: <div data-bbox="598 1498 1002 1901" style="border: 1px solid black; padding: 5px; margin: 10px 0;"> <div style="text-align: center; border: 1px solid black; width: fit-content; margin: 0 auto; padding: 2px;">Nozzle type</div> <p style="text-align: center;">Active: 01</p> <table style="width: 100%; border-collapse: collapse;"> <tr><td style="width: 20px;">01 (Orange)</td></tr> <tr><td>015 (Green)</td></tr> <tr><td>02 (Yellow)</td></tr> <tr><td>025 (Olive green)</td></tr> <tr><td>03 (Blue)</td></tr> </table> <div style="display: flex; justify-content: space-around; margin-top: 5px;"> <span>↓</span> <span>↓</span> <span>↓</span> </div> </div>	01 (Orange)	015 (Green)	02 (Yellow)	025 (Olive green)	03 (Blue)					
01 (Orange)												
015 (Green)												
02 (Yellow)												
025 (Olive green)												
03 (Blue)												

Step	Key	Action
4		Using the ARROW keys highlight the required nozzle type.
5		Press the ENTER key.
6		Repeat steps 2 to 5 for each of the 5 spray outlets.

## NOZZLE CONFIGURATION







The configuration for each of the 16 different nozzle types stored in the system can be altered.

The 11 pre-programmed nozzle types correspond to the ISO colouring system and we recommend that the configuration for these nozzles is **not** altered.

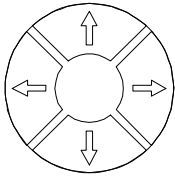
There are 5 programmable nozzle types for nozzles that are not colour coded (P1 to P5) and the following settings can be altered:

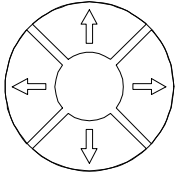
<b>Low limit:</b>	The lowest operating pressure of the nozzle.
<b>High limit:</b>	The highest operating pressure of the nozzle.
<b>Reference flow:</b>	The reference flow in litres per minute for the nozzle.
<b>Reference pressure:</b>	The pressure at which the above flow rate is true (ISO = 2 bar).

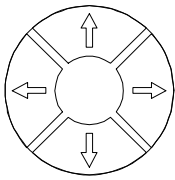
The procedure for altering the nozzle type configuration is as follows:

Step	Key	Action								
1		From the "Machine setup" menu select " <b>Nozzle configuration</b> ".								
2		Using the ARROW keys highlight the nozzle type to be altered.								
3		Press the ENTER key to select the configuration menu for the selected nozzle.								
4	 <div data-bbox="598 728 1005 1131" style="border: 1px solid black; padding: 10px; margin-top: 10px;"> <p style="text-align: center; border: 1px solid black; display: inline-block; padding: 2px;">Nozzle : P 1</p>   <table style="width: 100%; border-collapse: collapse;"> <tr> <td style="border-bottom: 1px solid black; padding: 2px;">Low limit</td> <td style="text-align: right; padding: 2px;">0.00</td> </tr> <tr> <td style="padding: 2px;">High limit</td> <td style="text-align: right; padding: 2px;">0.00</td> </tr> <tr> <td style="padding: 2px;">Ref. flow</td> <td style="text-align: right; padding: 2px;">0.00</td> </tr> <tr> <td style="padding: 2px;">Ref. pressure</td> <td style="text-align: right; padding: 2px;">0.00</td> </tr> </table> </div>	Low limit	0.00	High limit	0.00	Ref. flow	0.00	Ref. pressure	0.00	Using the ARROW keys highlight the setting to be adjusted.
Low limit	0.00									
High limit	0.00									
Ref. flow	0.00									
Ref. pressure	0.00									
5		Press the ENTER key when the setting to be altered is highlighted.								
6		Alter the value using the ARROW keys.								
7		Press the ENTER key to store the value.								
8		Repeat steps 4 to 7 for each of the settings								
9		Repeat steps 3 to 8 for each of the nozzle types to be altered.								

# OEM SETUP

**The OEM setup menu is password protected as the settings in this menu are directly related to the equipment fitted to the sprayer. All of the settings in the OEM setup menu are normally encoded when the LH 85 controller system is fitted to the machine and should not need altering thereafter.**

**For work and machine related settings please refer to the respective sections in this manual.**

The OEM menu structure is as follows:

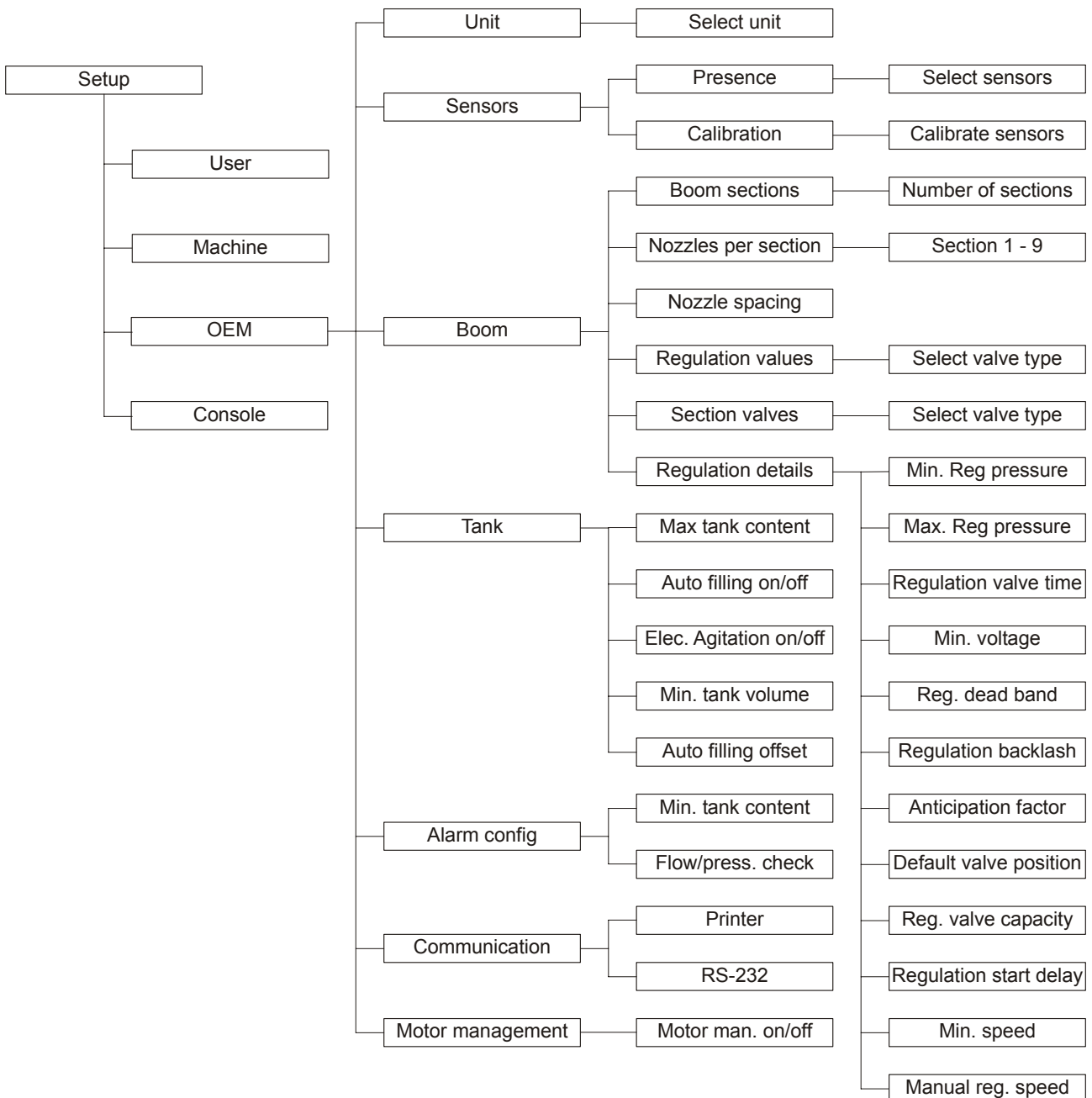

## UNIT

Encode the units with which the system should operate, the following units are available:

- SI (metric)
- US
- UK (imperial)

## SENSORS

In this menu the sensors found on the machine are selected and calibrated.

### PRESENCE

Select which of the following sensors are fitted to the machine:

- Wheel sensor
- Pressure sensor
- Flowmeter
- GPS
- Tank sensor

## CALIBRATION

### Pressure sensor:

To calibrate the pressure sensor the ADC values for no pressure and for maximum pressure must be found.

**No Pressure:** The minimum ADC value is measured when there is no pressure in the system.

**Pressure max:** The maximum working pressure, in bar, of the pressure sensor calculated from the ADC value for a reference pressure.

**Cal pressure:** A reference pressure used to calculate the maximum working pressure of the pressure sensor.

An automatic pressure sensor calibration procedure is available for calibrating the pressure sensor and the procedure is as follows:

***As there will almost always be a pressure drop between the pressure sensor and the nozzles we recommend measuring the actual pressure with a manometer fitted as close to the nozzles as possible during pressure sensor calibration.***

1. From "OEM setup" select "**Sensors**".
2. From "Sensors" select "**Calibration**".
3. From "Calibration" select "**Pressure sensor**".
4. Highlight "**No pressure**".
5. With **NO** pressure in the system press the AUTO key.
6. Confirm that there is no pressure in the system by pressing the ENTER key.
7. Highlight "**Cal pressure**" press the ENTER key.
8. Encode the reference pressure (standard = 5.0 bar) and press the ENTER key.
9. Highlight "**Pressure max**".
10. Press the AUTO key.
11. Increase the pressure on the sprayer until the manometer measures the encoded reference pressure (see step 8 in the above).
12. Press the ENTER key to complete pressure sensor calibration.

#### **Flow meter:**

The LH 85 Spray controller can be fitted with a spray flow meter and a fill flow meter.





The following must be encoded for each of the flow meters fitted on the sprayer:

- The minimum amount that the flow meter can measure in litres per minute.
- The maximum amount that the flow meter can measure in litres per minute.
- The number of pulses transmitted per litre by the flow meter.

The number of pulses per litre for the flow meter can be encoded directly from the flow meter calibration menu as follows:

1. From "OEM setup" select "**Sensors**".
2. From "Sensors" select "**Calibration**".
3. From "Calibration" select "**Flow meter**".
4. Select the flow meter for which the minimum and maximum flow rates are to be encoded by pressing the FLOW INPUT key. The text directly above the function keys shows which flow meter is being encoded.
5. Encode the number of pulses per litre for the flow meter.

The procedure to encode the minimum & maximum flow rates for the required flow meter plus an overview of the function keys follow:

Key	Description	Key	Description
	MIN FLOW key		FLOW INPUT key
	MAX FLOW key		CALIBRATE key

1. From "OEM setup" select "**Sensors**".
2. From "Sensors" select "**Calibration**".
3. From "Calibration" select "**Flow meter**".
4. Select the flow meter for which the minimum and maximum flow rates are to be encoded by pressing the FLOW INPUT key. The text directly above the function keys shows which flow meter is being encoded.
5. Press the MIN FLOW key.
6. Encode the **minimum** flow rate of the flow meter in litres per minute.
7. Press the ENTER key.
8. Press the MAX FLOW key.
9. Encode the **maximum** flow rate of the flow meter in litres per minute.
10. Press the ENTER key.

If the number of pulses per litre for the flow meter is not known or to make sure that the value is correct an automatic calibration function is available. A description of how to use the automatic calibration follows:

**Automatic flow meter calibration:**

1. From "OEM setup" select "**Sensors**".
2. From "Sensors" select "**Calibration**".
3. From "Calibration" select "**Flow meter**".
4. Select the flow meter for which the minimum and maximum flow rates are to be encoded by pressing the FLOW INPUT key. The text directly above the function keys shows which flow meter is being encoded.
5. Press the CALIBRATE key.
6. Press the ENTER key.
7. Press the START key and start spraying.
8. When minimum 100 litres has been sprayed stop spraying.
9. Press the STOP key and encode the actual amount sprayed.
10. Press the ENTER key and the flow meter is calibrated.

**Tank sensor:**

If the sprayer is fitted with a tank sensor this must be calibrated. The procedure for tank sensor calibration is as follows:

1. From "OEM setup" select "**Sensors**".
2. From "Sensors" select "**Calibration**".
3. From "Calibration" select "**Tank sensor**".
4. With an empty tank select "**Empty**".
5. Press the AUTO key then the ENTER key to confirm that there is **no** liquid on the tank sensor.
6. Press the ESCAPE key when calibration has finished.
7. Fill the tank to the encoded minimum tank level (see page 4.22) and select "**Min level**".
8. Press the AUTO key and then the ENTER key to confirm that the tank contains the number of litres encoded.
9. Press the ESCAPE key when calibration has finished.
10. Fill the tank completely and select "**Max level**".
11. Press the AUTO key and then the ENTER key to confirm that the tank is full.
12. Press the ESCAPE key when calibration has finished.
13. Select "**Tank shape**" and start emptying the tank by spraying with a constant flow between 60 – 120 litres per minute.
14. When the tank is empty tank sensor calibration is finished.

**BOOM**

All boom related settings are configured in the boom menu.



**BOOM SECTIONS**

Encode the number of boom sections on the sprayer.

**NOZZLES PER SECTION**

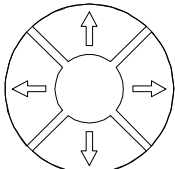
To encode the number of nozzles for each individual boom section do thus:

Step	Key	Action
1		From the "OEM" setup menu select " <b>Boom</b> ".
2		From the "Boom" menu select " <b>Nozzles per section</b> ".
3		Encode the number of nozzles on boom section 1 (starting from left using the ARROW UP and DOWN keys).

Step	Key	Action
4		Press the ENTER key.
5	 	Press the BOOM SECTION UP key to select the next boom section. <i>Pressing the BOOM SECTION DOWN key selects the previous boom section.</i>
6		Repeat steps 3 to 5 for each existing boom section.

## NOZZLE SPACING

Encode the distance between the nozzles in centimetres.

## REGULATION VALVES

If the regulation valve fitted to the sprayer bypasses the flow to the boom select "**Reg. valve bypass**".

If the regulation valve fitted to the sprayer throttles the flow select "**Reg valve throttle**".

## SECTION VALVES

Select whether the boom section valves are 2-way or 3-way.

## REGULATION DETAILS

The following settings determine the regulation process of the LH 85 Spray controller:

### Minimum regulation pressure:

Encode the pressure, in bar, that the sprayer may not go under.

*The working pressure will not go lower than this encoded level even if a lower pressure is required by the regulation system (the controller).*

*Should the actual pressure on the sprayer be lower than this encoded value the regulating system will continue to increase the pressure until the minimum pressure level has been reached.*

### Maximum regulation pressure:

Encode the pressure, in bar, that the sprayer may not go over.

*The working pressure will not go higher than this encoded level even if a higher pressure is required by the regulation system (the controller).*

*Should the actual pressure on the sprayer be higher than this encoded value the regulating system will continue to decrease the pressure until the maximum pressure level has been reached.*

**Regulation valve time:**

Encode the time, in seconds, that the regulation valve takes from fully closed to fully open (or fully open to fully closed).

*This value should be found by measuring the actual time the valve takes from fully closed to fully open (or the opposite) when the system is supplied with 12V.*

**Minimum voltage:**

Encode the lowest voltage at which the regulation valve starts to move.

*The controller uses variable voltage to control the valve; the closer the actual rate is to the target rate, the lower the voltage sent to the valve is. The minimum voltage must therefore be found when the valve is under pressure as this affects the force required to move the valve.*

**Regulation dead band:**

Encode an acceptable regulation dead band in percent.

*Regulation will stop when the difference between the target rate and the actual rate is lower than the encoded dead band (percent of the target rate). This is to prevent the valve from oscillating when the actual rate is near the target rate.*

**Regulation backlash:**

Encode the time in seconds it takes before the valve starts moving after a direction change.

**Anticipation factor:**

Encode the anticipation factor to ensure that the regulation valve is in a suitable position when switching the main valve on when, e.g. turning on the headland.

**0 = OFF**            The reg. valve remains stationary at the position when the main valve was switched off.

**100 = FULL**        The reg. valve will move completely to the calculated position.

*The number of boom sections open, the target rate, the average forward speed, the regulation valve time and the maximum reg. valve capacity are used to calculate a theoretical position of the regulation valve when the main valve is OFF, e.g. when turning on the headland.*

*The anticipation factor expresses how much of the time needed to reach the theoretical valve position will actually be used to drive the valve.*

*Example:            The calculated position will take 1 second to reach; setting the anticipation factor to 50% will result in the valve moving for ½ second instead of 1 second.*

**Default valve position:**

Encode the required position of the regulation valve in percent of fully open.

*When the main valve has been switched off for 10 minutes the reg. valve will move to this position.*

**Regulation valve capacity:**

Encode the capacity of the regulation valve in litres per minute.

**Regulation start delay:**

Encode the delay in seconds from when the main valve is switched on until regulation starts.

**Minimum forward speed:**

Encode the forward speed in kilometres per hour at which the system should automatically switch the main valve OFF.

**Manual regulation speed:**

Encode in percent of the regulation valve time how fast the regulation valve should move in manual operation.

**TANK**

Settings related to the main sprayer tank are encoded her. A description of the available settings follow:

**MAXIMUM TANK CONTENT**

Encode the maximum possible tank content in litres.

**AUTO FILLING**

Pressing the ENTER when this setting is highlighted switches automatic tank filling on and off.

**ELECTRIC AGITATION**

Pressing the ENTER key toggles between switching the automatic tank agitation start/stop function on and off.

**MINIMUM TANK VOLUME**

Encode the tank content at which tank agitation should automatically be switched off.

**AUTO FILLING OFFSET**

Encode the volume in litres that will still run into the tank after the fill valve has started shutting.

**ALARM CONFIGURATION**

The different warnings available are configured in this menu. The available warnings are described in the following:

**MINIMUM TANK CONTENT ALARM**

Encode the tank level, in litres, at which the tank content warning should be given.

**FLOW/PRESSURE CROSS-CHECK**

Encode the maximum permissible error in percent between the flow measured by the flow meter and the flow calculated from the pressure and nozzle characteristics.

**COMMUNICATION**

Select whether the communications port protocol is for a printer or for, e.g. a terminal for variable rate control (RS-232).

**MOTOR MANAGEMENT**

*This function is not currently available.*



Select whether the integrated motor management function is on or off.

---

**CONSOLE SETUP**

---

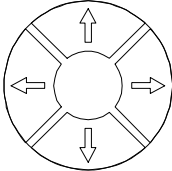
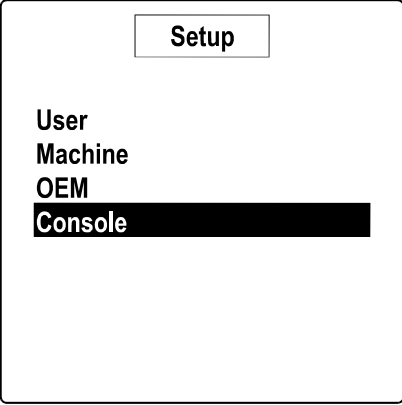

The "Console" settings relate directly to settings that alter the user interface of the console. The procedure to access the "Console" menu is similar to the procedure for accessing the other setup menus however the procedure is described below:

Step	Key	Action
1		Switch the main on/off switch (B6) to the <b>OFF</b> position.
2		Press the SETUP key.
3	 	Highlight the "Console" menu item using the ARROW UP and DOWN keys.
4		Press the ENTER key to select.

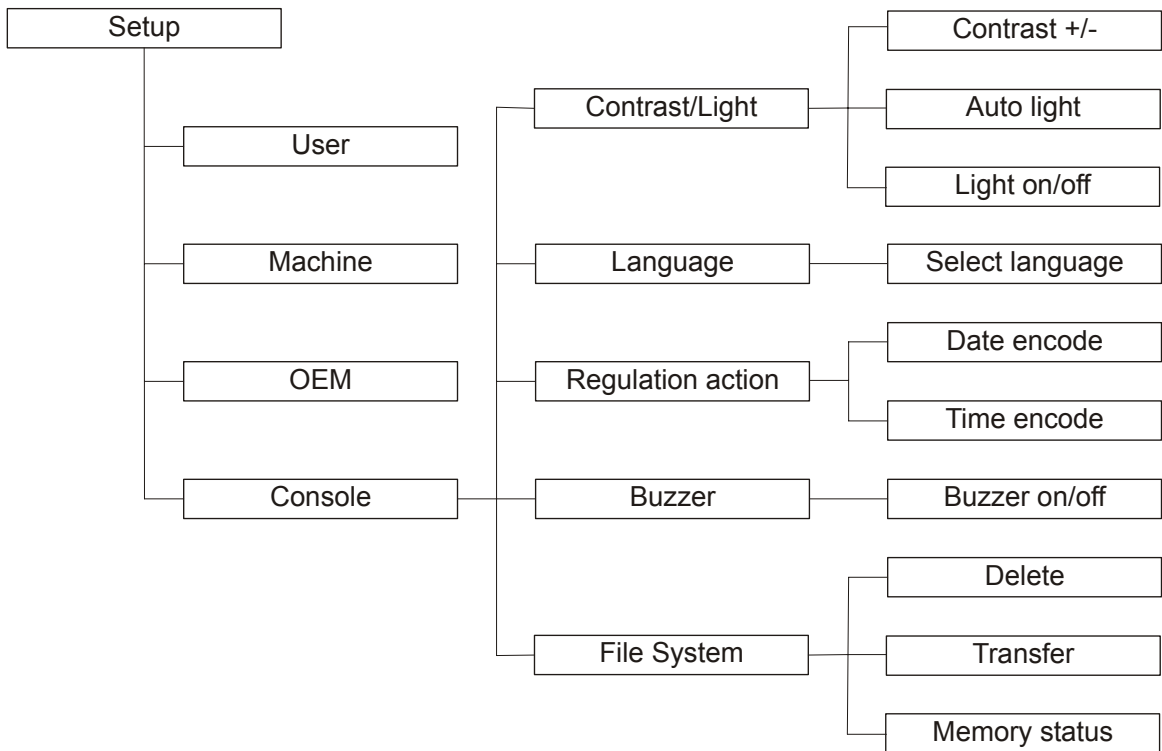
Once selected, the following menu structure is available, a detailed description of each setting can be seen after the diagram:

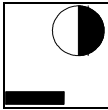
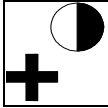

### CONTRAST/LIGHT

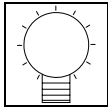
Key	Description
	Pressing this program key will make the screen lighter.
	Pressing this program key will make the screen darker.
	Pressing this program key will activate the auto-light function. The backlight is switched off until a key is pressed, the backlight will be switched on automatically.
	The display's backlight is turned on and off with this program key.

### LANGUAGE

Select the language of the LH 85 Spray controller.

### DATE/TIME

Encode the current date and time.

## **BUZZER**

Select whether the system sounds or not when a key is pressed.

## **FILE SYSTEM**

This menu allows the files stored in the system to be transferred & deleted.

The current memory status can also be seen.

For further information regarding transferring and deleting files please see the job function section of this manual (page 5.1).



# Job function

GENERAL JOB & COUNTER INFORMATION.....	5.2
JOB MENU OVERVIEW .....	5.3
STARTING A JOB .....	5.4
THE NOZZLE CALCULATOR .....	5.5
USING THE NOZZLE CALCULATOR.....	5.5
NOZZLE CALCULATOR EXAMPLE 1 .....	5.5
NOZZLE CALCULATOR EXAMPLE 2 .....	5.7
JOB AND COUNTER DATA MANAGEMENT .....	5.9
VIEWING JOBS AND COUNTER DATA.....	5.9
PRINTING JOBS AND COUNTER DATA .....	5.10
STORING JOBS AND COUNTER DATA.....	5.10
CLEARING JOB AND COUNTER DATA .....	5.11
TRANSFERRING JOB AND COUNTER DATA TO AN EXTERNAL DEVICE.....	5.11
CONNECTING THE LH 85 TO AN EXTERNAL DEVICE .....	5.11
VIEWING DATA TRANSFERRED FROM THE LH 85 SPRAY CONTROLLER.....	5.13
DELETING STORED FILES FROM THE LH 85 SPRAY CONTROLLER.....	5.13

---

## GENERAL JOB & COUNTER INFORMATION

---

There are 3 different counter sets in the LH 85 Spray Controller. Each job and counter set can be stored as a file on the system for retrieval at a later date.

**Jobs:** Up to 16 different jobs are available.  
Each job can be started and stopped independently of the other jobs.  
Each individual job can be viewed, printed, stored or cleared.  
Each job stores the following information:

<b>Nozzle:</b>	The nozzle type for the job.
<b>Application rate:</b>	The required application rate for the job.
<b>Start:</b>	The date & time that the job was started.
<b>Stop:</b>	The date & time that the job was stopped.
<b>Spray area:</b>	The area sprayed for the job.
<b>Spray distance:</b>	The distance covered for the job.
<b>Spray time:</b>	The time the job took in hours & minutes.
<b>Spray volume:</b>	The amount sprayed

**Campaign:** A total counter for e.g. the season.  
Data is constantly added to the campaign counter as work proceeds.  
The campaign counter can be viewed, printed, stored or cleared.  
A password is required to clear the campaign counter.  
The campaign counter stores the following information:

<b>Area:</b>	The area sprayed since the counter was cleared.
<b>Volume:</b>	The volume sprayed since the counter was cleared.
<b>Time:</b>	The time in hours & minutes for which the sprayer has been spraying.
<b>Max. speed:</b>	The maximum forward speed registered by the system.

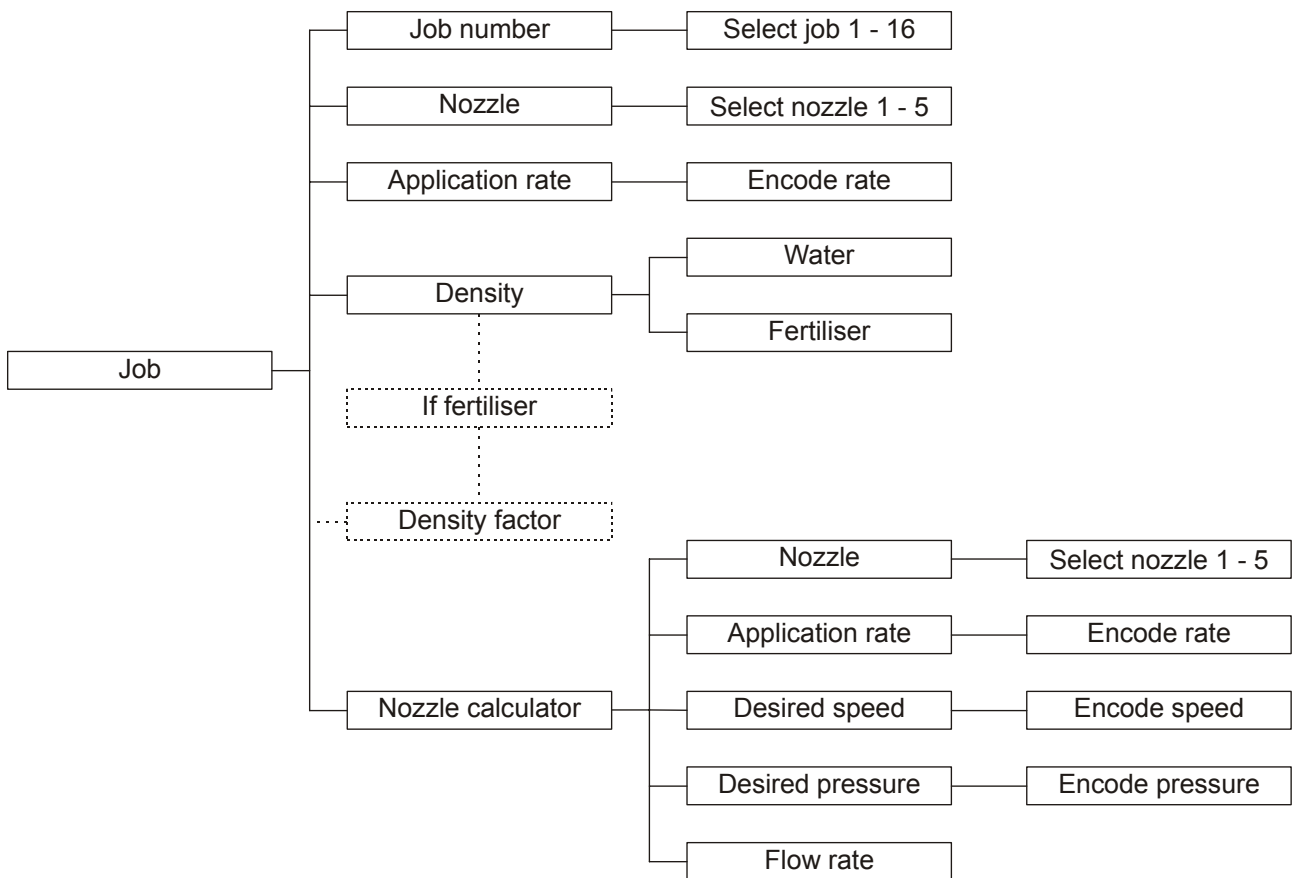

- Total:** A total counter for, e.g. the year.  
 Data is constantly added to the total counter as work proceeds.  
 The total counter can be viewed, printed, stored or cleared.  
 A password is required to clear the total counter.  
 The total counter stores the following information:
- Area:** The area sprayed since the counter was cleared.
  - Volume:** The volume sprayed since the counter was cleared.
  - Time:** The time in hours & minutes for which the sprayer has been spraying.
  - Max. speed:** The maximum forward speed registered by the system.

## JOB MENU OVERVIEW

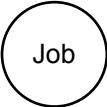
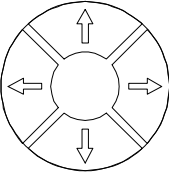

## STARTING A JOB

The procedure to start a job is as follows:

Step	Key	Action										
1		Switch the main on/off switch (B6) to the off position.										
2		<p>Press the JOB key and the following is displayed:</p> <div style="border: 1px solid black; padding: 10px; margin: 10px 0;"> <div style="border: 1px solid black; padding: 2px; text-align: center; margin-bottom: 5px;">Job</div> <table style="width: 100%; border-collapse: collapse;"> <tr> <td style="background-color: black; color: white; padding: 2px;"><b>Job number</b></td> <td style="padding: 2px;"><b>1</b></td> </tr> <tr> <td style="padding: 2px;">Nozzle</td> <td style="padding: 2px;">02</td> </tr> <tr> <td style="padding: 2px;">Application rate</td> <td style="padding: 2px;">158</td> </tr> <tr> <td style="padding: 2px;">Density</td> <td style="padding: 2px;">Water</td> </tr> <tr> <td style="padding: 2px;">Nozzle calculator</td> <td></td> </tr> </table> </div> <p>To select which job is to be active highlight "Job number" and press the ENTER key.                      Select the job number using the ARROW UP and DOWN keys and press the ENTER key.</p>	<b>Job number</b>	<b>1</b>	Nozzle	02	Application rate	158	Density	Water	Nozzle calculator	
<b>Job number</b>	<b>1</b>											
Nozzle	02											
Application rate	158											
Density	Water											
Nozzle calculator												
3		<p>Highlight "Nozzle" using the ARROW UP and DOWN keys and select which nozzle type is to be used for the job.  <i>The nozzle types shown here are the nozzle types encoded for the "Nozzle body" under "Machine setup" (page 4.12).</i>  <i>The nozzle/rate/speed/pressure combination can be checked using the "Nozzle calculator" which is described on page 5.5.</i></p>										
4		Press the ENTER key to select the required nozzle type.										
5		<p>Highlight "Application rate" using the ARROW UP and DOWN keys, then press the ENTER key.  <i>The nozzle/rate/speed/pressure combination can be checked using the "Nozzle calculator" which is described on page 5.5.</i></p>										
6		Encode the required application (target) rate for the job, then press the ENTER key.										
<i>Only if the density of the liquid to be used is <b>not</b> the same as water (1.00 kg/L)</i>												
7		Highlight "Density" and press the ENTER key.										
8		Highlight "Fertiliser" and press the ENTER key.										
9		Highlight "Density factor" and press the ENTER key.										
10		Encode the density of the liquid to be used, then press the ENTER key.										

# THE NOZZLE CALCULATOR

The nozzle calculator is a useful tool for deciding the following spray parameters:

- Nozzle type
- Application rate (target rate)
- Desired forward speed
- Desired spraying pressure

## USING THE NOZZLE CALCULATOR

The best way to describe how to use the nozzle calculator is to use examples, which follow:



### NOZZLE CALCULATOR EXAMPLE 1



In this example the following parameters are required:

Application rate = 150 L/ha

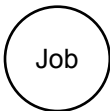
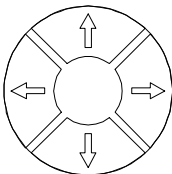
Nozzle type = 02 (Yellow)

Desired speed = 6.0 km/h

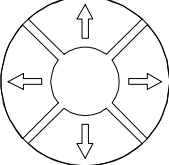
Step	Key	Action										
1		Switch the main on/off switch (B6) to the off position.										
2		Press the JOB key and a screen with similar values to the following is displayed: <div style="border: 1px solid black; padding: 5px; margin: 5px 0;"> <div style="text-align: center; border: 1px solid black; width: fit-content; margin: 0 auto; padding: 2px;">Job</div> <table style="width: 100%; border-collapse: collapse;"> <tr> <td style="background-color: #cccccc;"><b>Job number</b></td> <td style="text-align: right;"><b>1</b></td> </tr> <tr> <td>Nozzle</td> <td style="text-align: right;">015</td> </tr> <tr> <td>Application rate</td> <td style="text-align: right;">96</td> </tr> <tr> <td>Density</td> <td style="text-align: right;">Water</td> </tr> <tr> <td>Nozzle calculator</td> <td></td> </tr> </table> </div>	<b>Job number</b>	<b>1</b>	Nozzle	015	Application rate	96	Density	Water	Nozzle calculator	
<b>Job number</b>	<b>1</b>											
Nozzle	015											
Application rate	96											
Density	Water											
Nozzle calculator												
3		Highlight "Nozzle calculator" using the ARROW UP and DOWN keys.										
4		Press the ENTER key to select nozzle calculator and a screen with similar values to the following is displayed:										

Step	Key	Action										
		<div style="border: 1px solid black; padding: 10px; margin: 10px auto; width: fit-content;"> <p style="text-align: center; border: 1px solid black; display: inline-block;">Nozzle calculator</p> <table style="margin-top: 10px;"> <tr> <td><b>Nozzle</b></td> <td style="text-align: right;"><b>015</b></td> </tr> <tr> <td>Appl. rate</td> <td style="text-align: right;">96</td> </tr> <tr> <td>Desired speed</td> <td style="text-align: right;">6.0</td> </tr> <tr> <td>Desired pressure</td> <td style="text-align: right;">2.0</td> </tr> <tr> <td>Flow rate</td> <td style="text-align: right;">0.48</td> </tr> </table> </div>	<b>Nozzle</b>	<b>015</b>	Appl. rate	96	Desired speed	6.0	Desired pressure	2.0	Flow rate	0.48
<b>Nozzle</b>	<b>015</b>											
Appl. rate	96											
Desired speed	6.0											
Desired pressure	2.0											
Flow rate	0.48											
5		With "Nozzle" highlighted press the ENTER key.										
6		Highlight the required nozzle type from the list using the ARROW UP and DOWN keys.										
7		<p>Press the ENTER key to select the nozzle type and the display changes to display the following:</p> <div style="border: 1px solid black; padding: 10px; margin: 10px auto; width: fit-content;"> <p style="text-align: center; border: 1px solid black; display: inline-block;">Nozzle calculator</p> <table style="margin-top: 10px;"> <tr> <td><b>Nozzle</b></td> <td style="text-align: right;"><b>02</b></td> </tr> <tr> <td>Appl. rate</td> <td style="text-align: right;">150</td> </tr> <tr> <td>Desired speed</td> <td style="text-align: right;">6.0</td> </tr> <tr> <td>Desired pressure</td> <td style="text-align: right;">2.8</td> </tr> <tr> <td>Flow rate</td> <td style="text-align: right;">0.75</td> </tr> </table> </div> <p><i>As can be seen from the above, the nozzle type, the application rate and the desired speed have changed to the required values.</i></p> <p><i>The pressure required for the nozzle/rate/speed combination is shown as is the required flow rate for each nozzle (for calibration purposes).</i></p>	<b>Nozzle</b>	<b>02</b>	Appl. rate	150	Desired speed	6.0	Desired pressure	2.8	Flow rate	0.75
<b>Nozzle</b>	<b>02</b>											
Appl. rate	150											
Desired speed	6.0											
Desired pressure	2.8											
Flow rate	0.75											



**NOZZLE CALCULATOR EXAMPLE 2**



In this example the following parameters are required:

Application rate = 150 L/ha

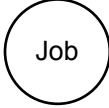
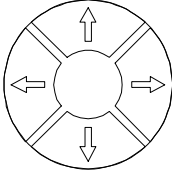
Nozzle type = 02 (Yellow)

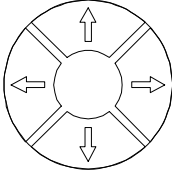
Desired pressure = 3.0 bar

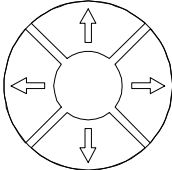
Step	Key	Action										
1		Switch the main on/off switch (B6) to the off position.										
2		Press the JOB key and a screen with similar values to the following is displayed:  <div style="border: 1px solid black; padding: 5px; width: fit-content; margin: 10px auto;"> <div style="text-align: center; border: 1px solid black; width: 50px; margin: 0 auto; padding: 2px;">Job</div> <table style="width: 100%; border-collapse: collapse;"> <tr> <td style="border-bottom: 1px solid black;"><b>Job number</b></td> <td style="text-align: right;"><b>1</b></td> </tr> <tr> <td><b>Nozzle</b></td> <td style="text-align: right;">015</td> </tr> <tr> <td><b>Application rate</b></td> <td style="text-align: right;">96</td> </tr> <tr> <td><b>Density</b></td> <td style="text-align: right;">Water</td> </tr> <tr> <td><b>Nozzle calculator</b></td> <td></td> </tr> </table> </div>	<b>Job number</b>	<b>1</b>	<b>Nozzle</b>	015	<b>Application rate</b>	96	<b>Density</b>	Water	<b>Nozzle calculator</b>	
<b>Job number</b>	<b>1</b>											
<b>Nozzle</b>	015											
<b>Application rate</b>	96											
<b>Density</b>	Water											
<b>Nozzle calculator</b>												
3		Highlight "Nozzle calculator" using the ARROW UP and DOWN keys.										
4		Press the ENTER key to select nozzle calculator and a screen with similar values to the following is displayed:  <div style="border: 1px solid black; padding: 5px; width: fit-content; margin: 10px auto;"> <div style="text-align: center; border: 1px solid black; width: 100px; margin: 0 auto; padding: 2px;">Nozzle calculator</div> <table style="width: 100%; border-collapse: collapse;"> <tr> <td style="border-bottom: 1px solid black;"><b>Nozzle</b></td> <td style="text-align: right;"><b>015</b></td> </tr> <tr> <td><b>Appl. rate</b></td> <td style="text-align: right;">96</td> </tr> <tr> <td><b>Desired speed</b></td> <td style="text-align: right;">6.0</td> </tr> <tr> <td><b>Desired pressure</b></td> <td style="text-align: right;">2.0</td> </tr> <tr> <td><b>Flow rate</b></td> <td style="text-align: right;">0.48</td> </tr> </table> </div>	<b>Nozzle</b>	<b>015</b>	<b>Appl. rate</b>	96	<b>Desired speed</b>	6.0	<b>Desired pressure</b>	2.0	<b>Flow rate</b>	0.48
<b>Nozzle</b>	<b>015</b>											
<b>Appl. rate</b>	96											
<b>Desired speed</b>	6.0											
<b>Desired pressure</b>	2.0											
<b>Flow rate</b>	0.48											
5		With "Nozzle" highlighted press the ENTER key.										
6		Highlight the required nozzle type from the list using the ARROW UP and DOWN keys.										

Step	Key	Action										
7		<p>Press the ENTER key to select the nozzle type and the display changes to display the following:</p> <div data-bbox="596 288 1003 692" style="border: 1px solid black; padding: 5px; margin: 10px 0;"> <p style="text-align: center;">Nozzle calculator</p> <table style="width: 100%; border-collapse: collapse;"> <tr> <td style="border-bottom: 1px solid black;"><b>Nozzle</b></td> <td style="text-align: right;"><b>02</b></td> </tr> <tr> <td>Appl. rate</td> <td style="text-align: right;">150</td> </tr> <tr> <td>Desired speed</td> <td style="text-align: right;">6.0</td> </tr> <tr> <td>Desired pressure</td> <td style="text-align: right;">2.8</td> </tr> <tr> <td>Flow rate</td> <td style="text-align: right;">0.75</td> </tr> </table> </div>	<b>Nozzle</b>	<b>02</b>	Appl. rate	150	Desired speed	6.0	Desired pressure	2.8	Flow rate	0.75
<b>Nozzle</b>	<b>02</b>											
Appl. rate	150											
Desired speed	6.0											
Desired pressure	2.8											
Flow rate	0.75											
8		<p>Highlight "Desired pressure" using the ARROW UP and DOWN keys.</p>										
9		<p>Press the ENTER key and encode the required pressure, then press the ENTER key to accept this value. The following is shown in the display:</p> <div data-bbox="596 1014 1003 1417" style="border: 1px solid black; padding: 5px; margin: 10px 0;"> <p style="text-align: center;">Nozzle calculator</p> <table style="width: 100%; border-collapse: collapse;"> <tr> <td style="border-bottom: 1px solid black;"><b>Nozzle</b></td> <td style="text-align: right;"><b>02</b></td> </tr> <tr> <td>Appl. rate</td> <td style="text-align: right;">150</td> </tr> <tr> <td>Desired speed</td> <td style="text-align: right;">6.2</td> </tr> <tr> <td>Desired pressure</td> <td style="text-align: right;">3.0</td> </tr> <tr> <td>Flow rate</td> <td style="text-align: right;">0.78</td> </tr> </table> </div> <p><i>As can be seen in the above, the nozzle type, the application rate and the required pressure have been changed to the required values.</i></p> <p><i>The required speed for the nozzle/rate/pressure combination is shown as is the required flow rate for each nozzle (for calibration purposes).</i></p>	<b>Nozzle</b>	<b>02</b>	Appl. rate	150	Desired speed	6.2	Desired pressure	3.0	Flow rate	0.78
<b>Nozzle</b>	<b>02</b>											
Appl. rate	150											
Desired speed	6.2											
Desired pressure	3.0											
Flow rate	0.78											

## JOB AND COUNTER DATA MANAGEMENT

As mentioned before each individual job plus the campaign and total counters can be viewed, printed, stored and cleared.

The procedure for each function is described in the following:

### VIEWING JOBS AND COUNTER DATA

The procedure to view job and counter data is as follows:

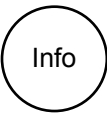
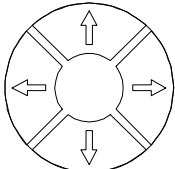
Step	Key	Action
1		Switch the main on/off switch (B6) to the off position.
2		<p>Press the INFO key and the following is displayed:</p> <div style="border: 1px solid black; padding: 10px; margin: 10px 0;"> <p style="text-align: center; border: 1px solid black; display: inline-block;">Counters</p></div> <div style="border: 1px solid black; padding: 5px; margin: 5px 0;"> <p><b>Jobs</b></p> <p>Campaign</p> <p>Total</p> </div>
3		<p>The job or counter data, which is described on page 5.2, are displayed.</p> <p><i>Job data is displayed on two screens. Use the ARROW UP and DOWN keys to alternate between these pages.</i></p>

## PRINTING JOBS AND COUNTER DATA

*It is only possible to print job and counter data if the system is fitted with a compatible printer and that the "Communication" menu item is set to "Printer" under console setup (see page 4.23).*

The procedure for printing job and counter data is as follows:

Step	Key	Action
1		Follow steps 1 and 2 as for viewing job and counter data.
2		Press the PRINT key and the selected job or counter will be printed.

## STORING JOBS AND COUNTER DATA

Job and counter data can be stored in the system for later retrieval.

This data is stored in the system as an \*.htm file. This type of file can be viewed in most internet browser software ensuring that the files stored in the LH 85 Spray controller can be viewed by most office computers and operating systems including hand-held devices.

The procedure for connecting the LH 85 Spray controller to an external device plus transferring job and counter data is described on page 5.11.

The procedure for storing job and counter data is as follows:

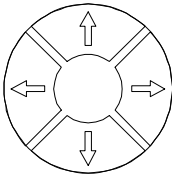
Step	Key	Action
1		Follow steps 1 and 2 as for viewing job and counter data.
2		Press the STORE key.
3		Alter the file name by selecting the letter to be altered with the ARROW LEFT or RIGHT keys. Then select the letter from the displayed list ARROW UP, DOWN, LEFT and RIGHT keys.
4		Press the ESCAPE key to leave the file name encode menu and press the ENTER key to save the file.

## CLEARING JOB AND COUNTER DATA

To clear job and counter data do as follows:

Step	Key	Action
1		Follow steps 1 and 2 as for viewing job and counter data.
2	<div style="border: 1px solid black; padding: 2px 10px; display: inline-block;">Clear</div>	Press the CLEAR key and the selected job or counter will be deleted. <b><i>The campaign and total counters require a password to be entered before the relevant data can be cleared.</i></b>

---

## TRANSFERRING JOB AND COUNTER DATA TO AN EXTERNAL DEVICE

---

As mentioned on page 5.10 job and counter data can be stored for later retrieval. These \*.htm files can be transferred from the LH 85 Spray controller to an external device such as a PC or a hand-held computer.

### CONNECTING THE LH 85 TO AN EXTERNAL DEVICE

The procedure for receiving files varies immensely depending on which platform the external device is built on.



Some systems/software allow files to be received directly, others do not.

The parameters required for the connection follow:

- Bits per second = 9600
- Data bits = 8
- Parity = none
- Stop bits = 1
- Flow control = none

The following is an example of how to transfer a file to, e.g. Windows XP via HyperTerminal (*HyperTerminal is a communications program included as part of MS Windows*):

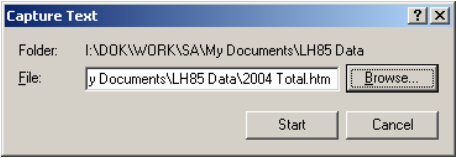
Step	Description
1	Start HyperTerminal ( <i>please refer to the operating systems operating instructions for information regarding how to start HyperTerminal</i> )
2	<div data-bbox="379 472 834 869"> </div> <div data-bbox="890 712 1385 869"> <p>Write a name for a the connection, e.g. "LH85-Connection"                      Select an icon for the connection.                      Click the OK button.</p> </div>
3	<div data-bbox="379 882 834 1328"> </div> <div data-bbox="890 1256 1369 1328"> <p>Select the serial COM port that is connected to the LH 85.</p> </div>
4	<div data-bbox="379 1341 834 1865"> </div> <div data-bbox="890 1794 1342 1865"> <p>Alter the properties of the serial connection as shown here.</p> </div>
5	Select "File" then "Save" to save the connection just created.

Step	Description
6	<div style="display: flex; justify-content: space-between;"> <div style="width: 45%;">  </div> <div style="width: 50%;"> <p>Select "Transfer" then "Capture Text". Browse for the location at which files should be saved.</p> <p>Alter the name of the file to, e.g. <i>Total 2004.htm</i>.</p> <p><b><i>It is important that the file extension is changed from *.txt to *.htm</i></b></p> <p>Press the "Start" button.</p> </div> </div>
7	Select the "File system" menu item in Console setup as described on page 4.23.
8	Select the file to be transferred using the ARROW UP and DOWN keys.
9	Press the  key and the selected file is transferred to the external device.
10	<p><i>If all of the stored files are to be saved in one file on the PC then simply select and transfer each file in the LH 85. Data will be added to the file just created on the PC.</i></p> <p>If each stored file in the 85 is to be saved as individual files on the PC then:</p> <ul style="list-style-type: none"> <li>• Select Transfer/Capture Text/Stop in HyperTerminal after each transfer is complete.</li> <li>• Repeat step 6, renaming the file name for each file to be transferred until all required files have been transferred.</li> </ul>
11	Once all stored data have been transferred close HyperTerminal.

### VIEWING DATA TRANSFERRED FROM THE LH 85 SPRAY CONTROLLER

To view data transferred from the LH 85 spray controller to, e.g. a PC running Windows simply open the \*.htm file created when transferring data (as described above). Depending on how the PC system is setup, double-clicking the file normally opens the file in the preferred internet browser.

For information on the contents of the file please see page 5.2.

### DELETING STORED FILES FROM THE LH 85 SPRAY CONTROLLER

Step	Key	Action
1		Connect the LH 85 Spray Controller to the external device as described above.
2		Select the "File system" menu item in Console setup as described on page 4.23.
3		Select the file to be deleted using the ARROW UP and DOWN keys.
4		Press the DELETE key and the selected file is deleted from the LH 85 Spray controller.



# System

DIAGNOSTICS .....	6.2
TEST INPUT .....	6.2
TEST OUTPUT .....	6.3

## DIAGNOSTICS

### TEST INPUT

The "Test input" menu should be used if a sensor is suspected to be faulty.

For each input description there is, on the right-hand side of the display, a counter that registers the number of times that the input in question has been activated (this counter is reset each time "Test input" is exited or by pressing the C key).

The different inputs can be paged through by pressing the ARROW UP and DOWN keys (there are 4 input pages).

The different input descriptions relate to the following:

Input	Description
<b>Wheel</b>	Forward speed signal from the speed sensor fitted to the tractor (via the DIN/ISO socket in the tractor cab).
<b>Radar</b>	Forward speed signal from the radar fitted to the tractor (via the DIN/ISO socket in the tractor cab).
<b>Impl. Wheel</b>	Forward speed signal from a speed sensor fitted on the sprayer
<b>Flow 1</b>	Signal from a flow meter fitted on the sprayer.
<b>Pres. Sensor</b>	The current measured from a pressure sensor fitted on the sprayer in mA.
<b>Master In</b>	Current master switch status (HI or LO).
<b>Press the ARROW DOWN key to see the next inputs:</b>	
<b>Section 1 – 5</b>	Current boom section status for boom sections 1 to 5 (HI or LO).
<b>Press the ARROW DOWN key to see the next inputs:</b>	
<b>Section 6 – 9</b>	Current boom section status for boom sections 6 to 9 (HI or LO).
<b>Press the ARROW DOWN key to see the next inputs:</b>	
<b>Flow 2</b>	Signal from a fill flow meter fitted on the sprayer.
<b>Tank</b>	Signal from the tank level sensor fitted to the sprayer tank.
<b>Wind speed</b>	Signal from an anemometer.

## TEST OUTPUT

Each individual output can be tested here.

Highlight an output to be tested using the ARROW UP and DOWN keys then press the ENTER key to change the status of the selected output:

Output	Description
<b>Liq valve PWM</b>	Press the ENTER key and encode a value from 0 to 100 (e.g. 50) the regulation valve will be sent a signal corresponding to the encoded percentile value (e.g. 50%) duty cycle when the "Liq valve enable" is set to "On".
<b>Liq valve enable</b>	Press the ENTER key and the valve is sent the above encoded duty cycle percent (status = "On"). Press the ENTER key once more and the valve will shut (status = "Off").
<b>Liq valve DIR</b>	This changes the direction of the main valve during test. When "On" the valve will run in the direction for opening. When "Off" the valve will run in the direction for shutting.
<b>Agitation Out</b>	Press the ENTER key and tank agitation will start (status = "On"). Press the ENTER key once more and agitation will stop (status = "Off").
<b>Master Valve Out</b>	Press the ENTER key and the main valve will open (status = "On"). Press the ENTER key once more and the main valve will close (status = "Off").
<b>Fill Valve Out</b>	Press the ENTER key and the fill valve will open (status = "On"). Press the ENTER key once more and the fill valve will close (status = "Off").



# Index & Notes

INDEX.....	7.2
NOTES .....	7.5

---

**INDEX**

---

<b>-A-</b>	
Active alarms .....	3.4
Agitation .....	4.22
Agitation Out .....	6.3
Agitation switch .....	2.4
Alarm for flow/pressure cross-check ..	4.23
Alarm for minimum tank content .....	4.22
Alarm log .....	3.4
Alarms .....	3.4, 4.22
Altering values .....	2.9
Anemometer input .....	6.2
Anticipation factor .....	4.21
Application rate .....	2.5
Area covered .....	3.2
Area left .....	3.2
Arrow keys .....	2.7
Auto/Man function switches .....	2.4
Automatic flow meter calibration .....	4.18
Automatic flowmeter correction .....	4.10
Automatic shut off .....	4.22
Automatic speed calibration .....	4.7
Automatic tank filling .....	4.22
<b>-B-</b>	
Backlash .....	4.21
Backlight .....	4.24
Baud rate .....	5.11
Beeper .....	4.25
Boon sections .....	4.19
Boost .....	2.6, 4.11
Buzzer .....	4.25
<b>-C-</b>	
Campaign counters .....	3.4, 5.2
Capacity .....	4.22
Checkboxes .....	2.12
Clear key .....	2.7
Com-port .....	5.12
Configuring nozzle types .....	4.13
Configuring the nozzle body .....	4.12
Console setup .....	4.23
Contrast .....	4.24
Controller, info menu .....	3.4
counter viewing .....	5.9
Counters .....	5.2
Counters, info menu .....	3.4
<b>-D-</b>	
Data bits .....	5.11
Data management .....	5.9
Data transfer .....	4.25, 5.11
Date/time .....	4.24
Dead band .....	4.21
Default valve position .....	4.21
Deleting files .....	4.25
Density .....	3.2
Diagnostics .....	3.4, 6.2
Distance between nozzles .....	4.20
Distance covered .....	3.3
Distance left .....	3.3
<b>-E-</b>	
Efficiency .....	3.2
Elapsed time .....	3.3
Electric agitation .....	4.22
Encoding the boost % .....	4.11
Enter key .....	2.7
Escape key .....	2.7
<b>-F-</b>	
Fast regulation value .....	4.11
Fast setup .....	3.4
File system .....	4.25
Files .....	5.10
Fill flow input .....	6.2
Fill function switch .....	2.4
Fill offset .....	4.22

<i>Fill Valve Out</i> .....	6.3	<i>Main on/off switch</i> .....	2.4
<i>Flow control (data)</i> .....	5.11	<i>Manual flowmeter correction</i> .....	4.11
<i>Flow input</i> .....	6.2	<i>Manual rate control</i> .....	3.5
<i>Flow meter</i> .....	4.17	<i>Manual regulation speed</i> .....	4.22
<i>Flow meter calibration</i> .....	4.18	<i>Manual speed calibration</i> .....	4.8
<i>Flow rate</i> .....	3.2	<i>Master Valve Out</i> .....	6.3
<i>Flow/pressure cross-check</i> .....	4.23	<i>Maximum pressure</i> .....	4.20
<i>flowmeter correction, Automatic</i> .....	4.10	<i>Maximum tank content</i> .....	4.22
<i>flowmeter correction, manual</i> .....	4.11	<i>Memory information</i> .....	4.25
<i>Flowmeter or pressure sensor</i> .....	3.6	<i>Memory left</i> .....	4.25
<i>Forward speed</i> .....	3.2	<i>Memory remaining</i> .....	4.25
<i>Function keys</i> .....	2.8	<i>Metric units</i> .....	4.16
	-G-	<i>Minimum forward speed</i> .....	4.22
<i>Go to manual</i> .....	3.5	<i>Minimum pressure</i> .....	4.20
	-H-	<i>Minimum tank content alarm</i> .....	4.22
<i>HTM-files</i> .....	5.13	<i>Minimum tank volume</i> .....	4.22
<i>HyperTerminal</i> .....	5.12	<i>Minimum voltage</i> .....	4.21
	-I-		-N-
<i>Imperial units</i> .....	4.16	<i>Nozzle spacing</i> .....	4.20
<i>Implement wheel</i> .....	4.5	<i>Nozzle type</i> .....	2.5
<i>Implement wheel input</i> .....	6.2	<i>Nozzles per section</i> .....	4.19
<i>Import/Export</i> .....	3.4	<i>Number of boom sections</i> .....	4.19
<i>Info key</i> .....	2.6		-O-
<i>Info menu</i> .....	3.3	<i>OEM Pressure sensor calibration</i> .....	4.16
<i>Initial OEM Sensor calibration</i> .....	4.16	<i>OEM setup</i> .....	4.15
<i>Initial pressure sensor calibration, OEM</i> .....	4.16	<i>Operating pressure</i> .....	2.5, 3.2
	-J-	<i>Operation</i> .....	3.2
<i>Job counters</i> .....	3.4, 5.2	<i>Optimum pressure</i> .....	2.5
<i>Job function</i> .....	2.7		-P-
<i>Job key</i> .....	2.7	<i>Parity</i> .....	5.11
<i>Job viewing</i> .....	5.9	<i>PC</i> .....	5.11
	-L-	<i>Power switch</i> .....	2.4
<i>Language</i> .....	4.24	<i>Precise regulation action</i> .....	4.12
<i>Liq valva DIR</i> .....	6.3	<i>Pressure</i> .....	2.5, 3.2
<i>Liq valve enable</i> .....	6.3	<i>Pressure sensor or flowmeter</i> .....	3.6
<i>Liq valve PWM</i> .....	6.3	<i>Pressure sensor input</i> .....	6.2
	-M-	<i>Printer</i> .....	4.23
<i>Machine setup</i> .....	4.4	<i>Printing data</i> .....	5.10

**-R-**

Radar	4.5
Radar input	6.2
Rate	2.5
Regulation action	4.11
Regulation base	3.6
Regulation pressure	4.20
Regulation speed	4.22
Regulation start delay	4.22
Regulation valve capacity	4.22
Regulation valve time	4.21
Regulation valve types	4.20
Remaining area	3.2
Remaining volume	3.2
RS-232	4.23

**-S-**

saving counters	5.10
Saving jobs	5.10
Section valve type	4.20
Selecting a value	2.9
Selecting a value from a list	2.12
Selecting menus	2.9
Selecting values	2.12
Sensor calibration, OEM	4.16
Sensor presence	4.16
Sensor test	6.2
Serial port	4.23
Setup	2.6
Setup key	2.6
SI Units	4.16
Simulated speed	4.8
Speed calibration	4.7, 4.8
Speed simulation	4.8
Speed source	3.5, 4.5
Spray rate	2.5
Spray related information	2.6, 3.2

Sprayed volume	3.2
Sprayer wheel input	6.2
Start delay	4.22
Starting a job	5.4
Stop bits	5.11

**-T-**

Tank filling	4.4
Tank level	4.4
Tank sensor calibration	4.19
Tank sensor input	6.2
Test input	3.4, 6.2
Test output	3.4, 6.3
Time/date	4.24
Total counters	3.4, 5.3
Tractor wheel	4.5
Transferring files	4.25

**-U-**

Units	4.16
US Units	4.16
User setup	4.3
Using the nozzle calculator	5.5

**-V-**

Valve backlash	4.21
Valve capacity	4.22
Valve delay	4.22
Valve position	4.21
Valve type	4.20
Viewing data	5.9
Viewing jobs	5.9
Volume left	3.2

**-W-**

Wheel input	6.2
Wind speed	3.3
Work related information	2.6, 3.2
Working pressure	2.5, 3.2
Working width, current	3.2

---

## NOTES

---





